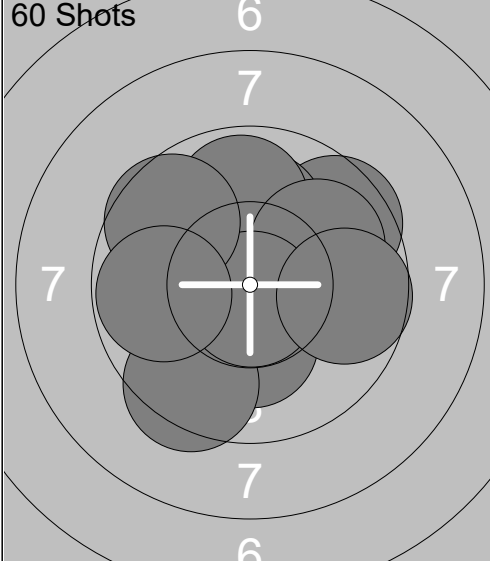
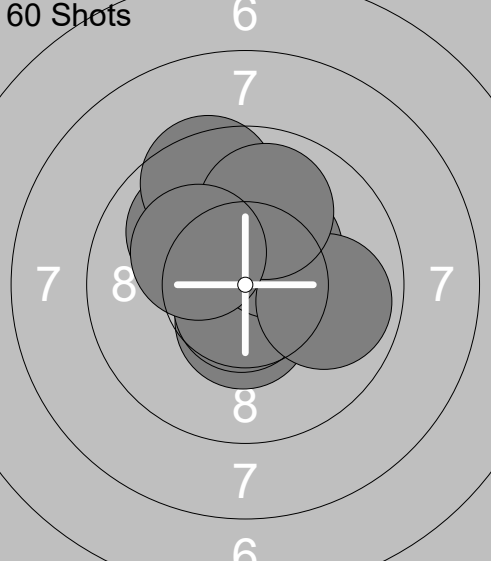
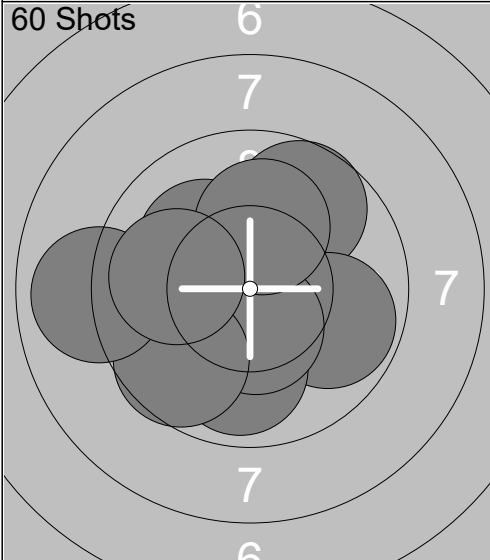
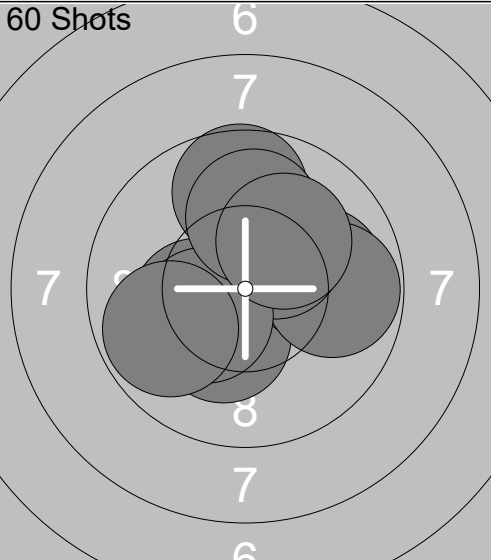
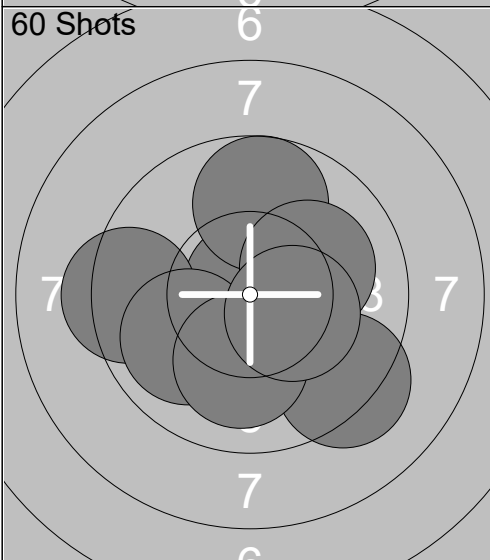
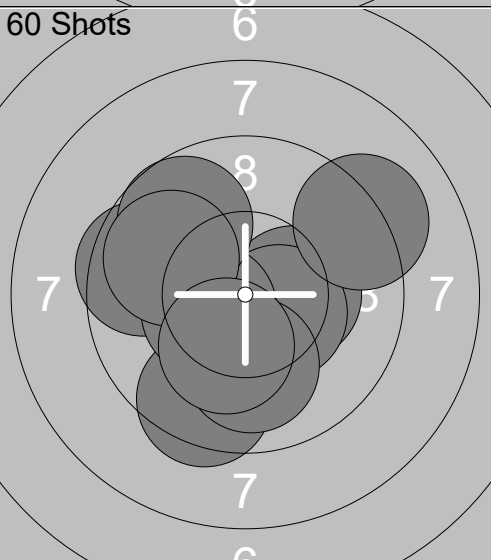

<p>60 Shots</p> 	<p>1: 9.6 ↗ 2: 10.2x ↓ 3: 10.1 ↑ 4: 9.4 ↙ 5: 9.9 ↑ 6: 9.9 ↗ 7: 10.8x ↓ 8: 9.7 → 9: 9.6 ↖ 10: 9.8 ←</p> <p>Series 99.0 99.0</p>	<p>60 Shots</p> 	<p>11: 10.5x ↓ 12: 10.5x ↑ 13: 10.8x ← 14: 10.0 ↖ 15: 10.7x ↓ 16: 9.5 ↑ 17: 10.4x ↗ 18: 9.9 → 19: 9.9 ↑ 20: 10.2x ↖</p> <p>Series 102.4 201.4</p>
<p>60 Shots</p> 	<p>21: 10.1 ↖ 22: 9.7 ↗ 23: 10.0 ← 24: 9.8 → 25: 9.9 ↓ 26: 10.4x ↓ 27: 9.6 ↙ 28: 10.1 ↑ 29: 8.9 ← 30: 10.0 ←</p> <p>Series 98.5 299.9</p>	<p>60 Shots</p> 	<p>31: 9.7 ↑ 32: 10.3x ↓ 33: 10.3x ← 34: 10.0 → 35: 9.8 → 36: 10.3x ↗ 37: 10.3x ↙ 38: 10.0 ↑ 39: 10.1 ↗ 40: 9.8 ←</p> <p>Series 100.6 400.5</p>
<p>60 Shots</p> 	<p>41: 10.4x ↗ 42: 10.5x → 43: 10.8x ↑ 44: 9.4 ← 45: 9.7 ↑ 46: 10.0 ↙ 47: 9.3 ↘ 48: 10.1 ↓ 49: 10.1 ↗ 50: 10.3x →</p> <p>Series 100.6 501.1</p>	<p>60 Shots</p> 	<p>51: 9.6 ← 52: 10.3x → 53: 10.4x → 54: 9.5 ↓ 55: 10.0 ↓ 56: 10.4x ↙ 57: 9.7 ↖ 58: 9.9 ↖ 59: 9.1 ↗ 60: 10.2x ↓</p> <p>Series 99.1 600.2</p>

Relay <b>5</b>	Lane <b>4</b>	<b>Haeon Lee</b>
-------------------	------------------	------------------

WVU Mobile Range			
------------------	--	--	--

18.11.2023	Walther Cup 2023	West Virginia University
------------	------------------	--------------------------

Comment	Signature
---------	-----------

<p>60 Shots</p>	<p>1: 8.6 → 2: 10.2x ↗ 3: 9.2 ↓ 4: 9.1 ↗ 5: 9.7 ↑ 6: 8.6 ↗ 7: 9.5 → 8: 8.9 ↓ 9: 10.6x ← 10: 9.6 ↗</p> <p>Series 94.0 94.0</p>	<p>60 Shots</p>	<p>11: 9.4 ↓ 12: 7.7 → 13: 8.7 ↑ 14: 10.1 ↓ 15: 8.6 ↗ 16: 8.0 → 17: 8.4 ↓ 18: 8.8 ↑ 19: 10.3x ← 20: 9.9 ←</p> <p>Series 89.9 183.9</p>
<p>60 Shots</p>	<p>21: 8.0 ↓ 22: 10.3x ↗ 23: 8.8 ← 24: 9.3 ↗ 25: 9.6 ↑ 26: 10.0 → 27: 7.4 ↓ 28: 9.3 → 29: 8.7 → 30: 9.6 ↑</p> <p>Series 91.0 274.9</p>	<p>60 Shots</p>	<p>31: 9.3 ↗ 32: 9.0 ← 33: 9.8 ← 34: 8.9 ← 35: 10.3x ↗ 36: 8.5 ↗ 37: 10.0 ↑ 38: 7.6 → 39: 9.6 ← 40: 10.7x ↗</p> <p>Series 93.7 368.6</p>
<p>60 Shots</p>	<p>41: 9.5 ↓ 42: 10.1 ↓ 43: 9.9 ↗ 44: 10.7x ↗ 45: 9.2 ↑ 46: 9.8 ↗ 47: 9.7 → 48: 9.4 ↑ 49: 9.8 ← 50: 9.4 ↗</p> <p>Series 97.5 466.1</p>	<p>60 Shots</p>	<p>51: 9.4 ↗ 52: 10.4x → 53: 10.2x ↑ 54: 9.5 ↑ 55: 10.3x ↓ 56: 9.8 ← 57: 9.5 ↑ 58: 9.6 ↗ 59: 10.5x ↓ 60: 9.7 →</p> <p>Series 98.9 565.0</p>

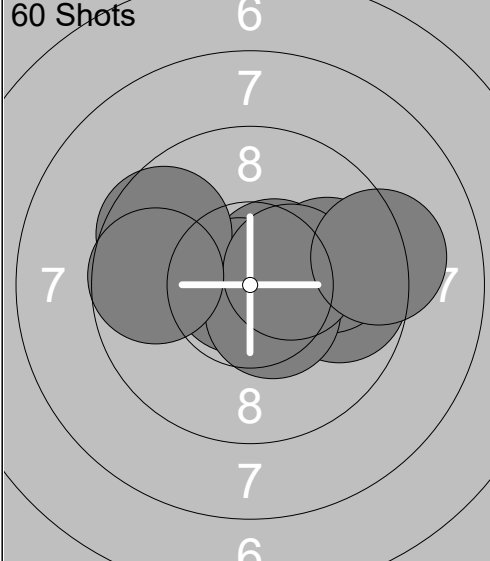
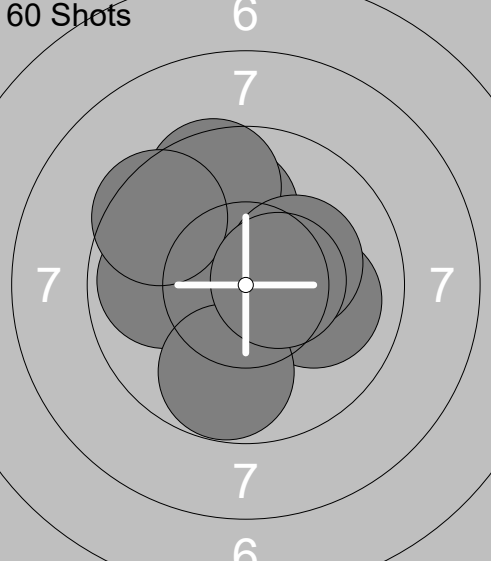
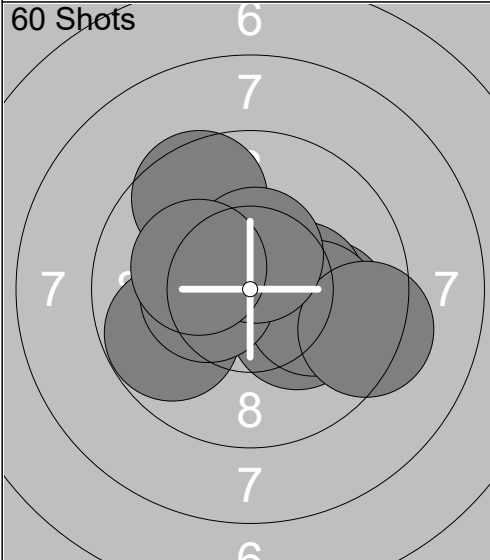
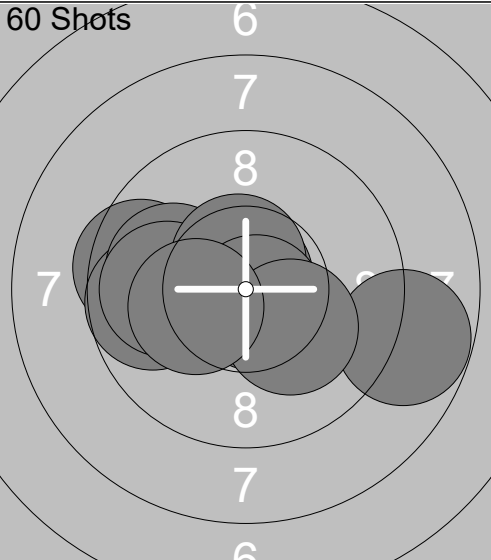
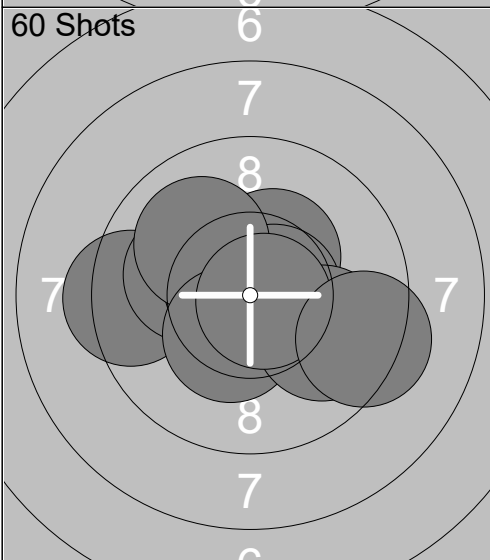
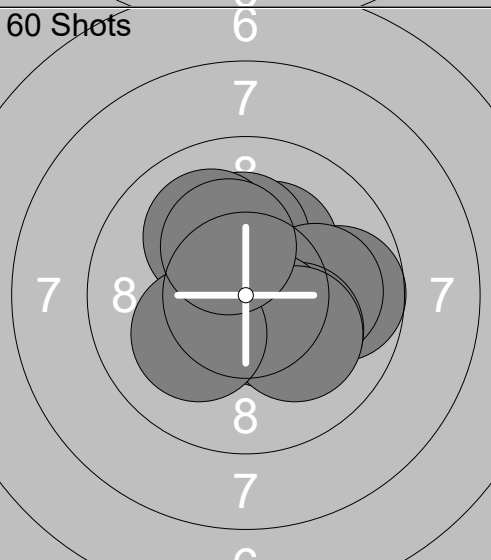
<p>60 Shots</p> 	<p>1: 10.6x ↘ 2: 10.5x ↗ 3: 9.8 → 4: 10.8x ← 5: 9.9 → 6: 10.5x ↘ 7: 9.6 ↖ 8: 10.4x → 9: 9.2 → 10: 9.7 ←</p> <p>Series 101.0 101.0</p>	<p>60 Shots</p> 	<p>11: 10.4x ← 12: 10.0 ↑ 13: 10.0 → 14: 10.5x ↑ 15: 9.9 ← 16: 9.6 ↑ 17: 9.5 ↖ 18: 10.2x ↗ 19: 9.8 ↓ 20: 10.5x →</p> <p>Series 100.4 201.4</p>
<p>60 Shots</p> 	<p>21: 10.0 → 22: 10.3x → 23: 10.2x ↘ 24: 9.8 ← 25: 9.6 ↑ 26: 10.1 → 27: 10.4x ← 28: 9.3 → 29: 10.5x ↑ 30: 10.2x ←</p> <p>Series 100.4 301.8</p>	<p>60 Shots</p> 	<p>31: 10.8x ↑ 32: 9.5 ← 33: 9.7 ← 34: 10.0 ← 35: 8.8 → 36: 9.9 ← 37: 10.6x ↑ 38: 10.7x ↘ 39: 10.2x ↘ 40: 10.3x ←</p> <p>Series 100.5 402.3</p>
<p>60 Shots</p> 	<p>41: 10.4x ↗ 42: 9.4 ← 43: 10.1 ↖ 44: 10.7x ↖ 45: 10.6x → 46: 10.0 ↗ 47: 10.4x ↘ 48: 9.9 ↘ 49: 10.8x → 50: 9.3 ↘</p> <p>Series 101.6 503.9</p>	<p>60 Shots</p> 	<p>51: 9.7 → 52: 10.3x ↗ 53: 10.2x ↑ 54: 10.0 → 55: 10.0 ↗ 56: 10.1 ↘ 57: 10.5x ↘ 58: 10.1 ↘ 59: 10.1 ↖ 60: 10.3x ↑</p> <p>Series 101.3 605.2</p>

Relay	Lane	<h1>Marissa Musgrave</h1>
<b>5</b>	<b>6</b>	

WVU Mobile Range		
------------------	--	--

18.11.2023	Walther Cup 2023	West Virginia University
------------	------------------	--------------------------

Comment	Signature
---------	-----------

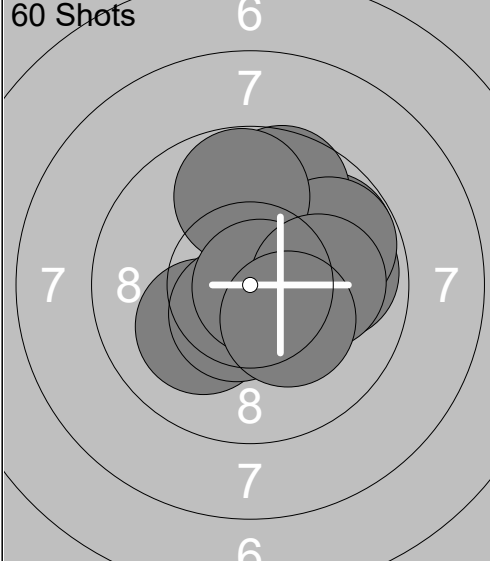
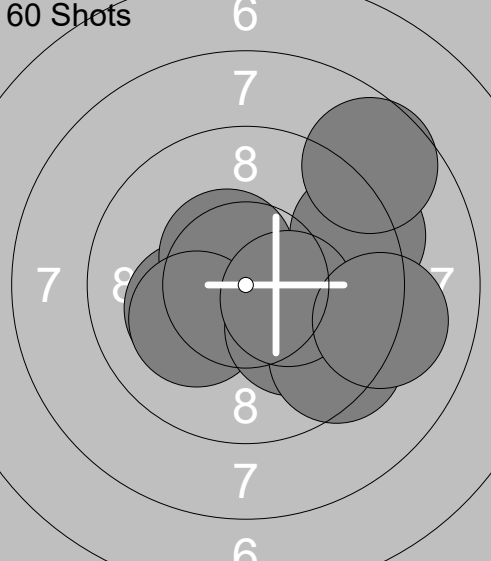
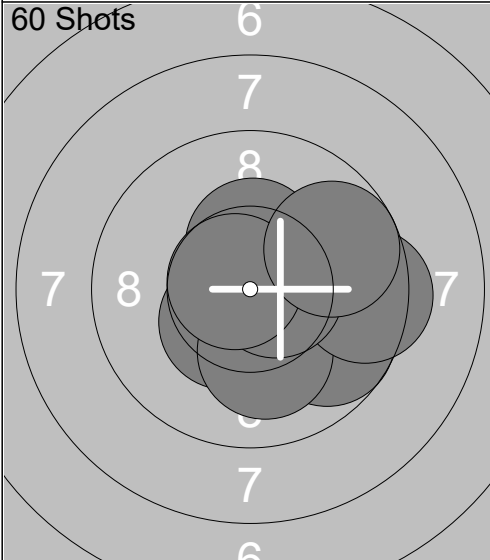
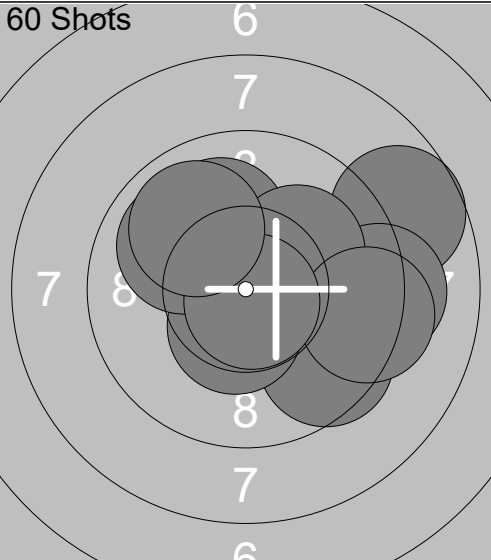
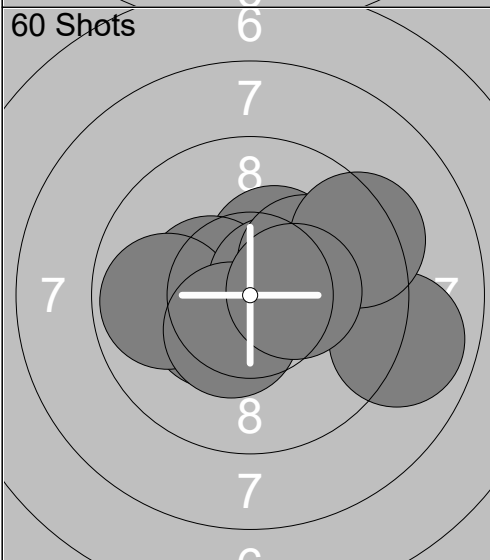
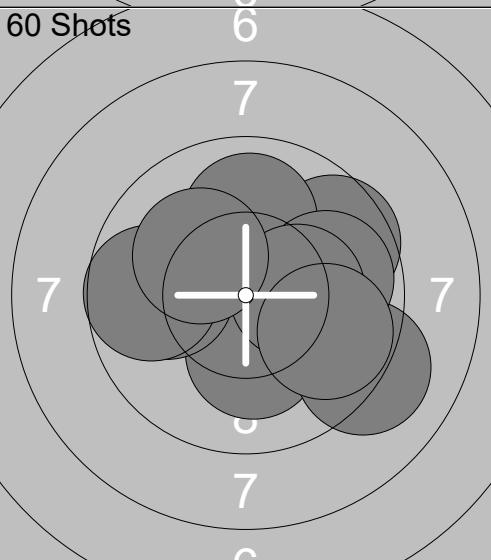
<p>60 Shots</p> 	<p>1: 9.8 →</p> <p>2: 9.7 ↑</p> <p>3: 10.1 ↙</p> <p>4: 9.9 →</p> <p>5: 9.8 →</p> <p>6: 9.8 ↑</p> <p>7: 10.5x ↓</p> <p>8: 10.8x →</p> <p>9: 10.0 →</p> <p>10: 10.3x ↘</p> <p>Series 100.7</p> <p style="text-align: center;">100.7</p>	<p>60 Shots</p>  <p>11: 9.5 ↘</p> <p>12: 10.2x ↙</p> <p>13: 10.5x ↗</p> <p>14: 10.2x ↙</p> <p>15: 9.3 →</p> <p>16: 8.7 ↗</p> <p>17: 10.1 ↘</p> <p>18: 9.4 ↘</p> <p>19: 10.4x →</p> <p>20: 9.1 →</p> <p>Series 97.4</p> <p style="text-align: center;">198.1</p>
<p>60 Shots</p> 	<p>21: 10.6x →</p> <p>22: 10.3x ↘</p> <p>23: 10.4x ↑</p> <p>24: 10.4x ↙</p> <p>25: 9.7 ↘</p> <p>26: 10.1 ↓</p> <p>27: 9.4 →</p> <p>28: 10.6x →</p> <p>29: 10.7x ↙</p> <p>30: 9.7 →</p> <p>Series 101.9</p> <p style="text-align: center;">300.0</p>	<p>60 Shots</p>  <p>31: 8.7 →</p> <p>32: 9.5 ↘</p> <p>33: 10.1 ↑</p> <p>34: 10.4x ↓</p> <p>35: 10.0 ↙</p> <p>36: 9.2 →</p> <p>37: 10.1 ↗</p> <p>38: 9.3 →</p> <p>39: 10.8x ↓</p> <p>40: 9.9 ↗</p> <p>Series 98.0</p> <p style="text-align: center;">398.0</p>
<p>60 Shots</p> 	<p>41: 10.3x ↗</p> <p>42: 10.4x ↙</p> <p>43: 10.4x ↙</p> <p>44: 9.9 ←</p> <p>45: 8.9 →</p> <p>46: 10.6x →</p> <p>47: 10.1 ↗</p> <p>48: 10.4x ↙</p> <p>49: 9.4 →</p> <p>50: 10.4x →</p> <p>Series 100.8</p> <p style="text-align: center;">498.8</p>	<p>60 Shots</p>  <p>51: 9.6 ↗</p> <p>52: 10.0 ↑</p> <p>53: 10.2x ↓</p> <p>54: 9.1 ↘</p> <p>55: 9.9 →</p> <p>56: 9.9 ←</p> <p>57: 9.7 ←</p> <p>58: 10.3x →</p> <p>59: 9.8 ↘</p> <p>60: 10.2x ↙</p> <p>Series 98.7</p> <p style="text-align: center;">597.5</p>

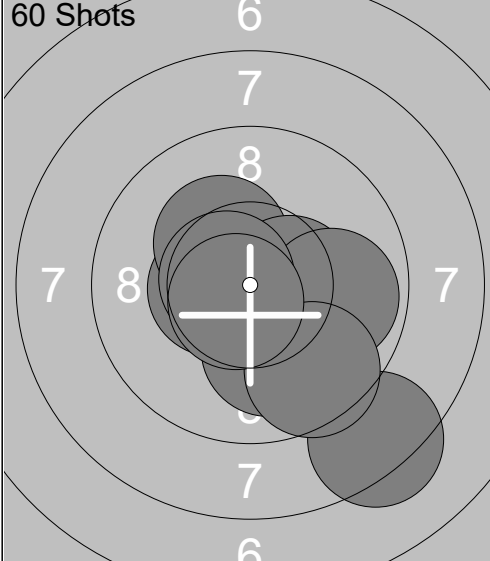
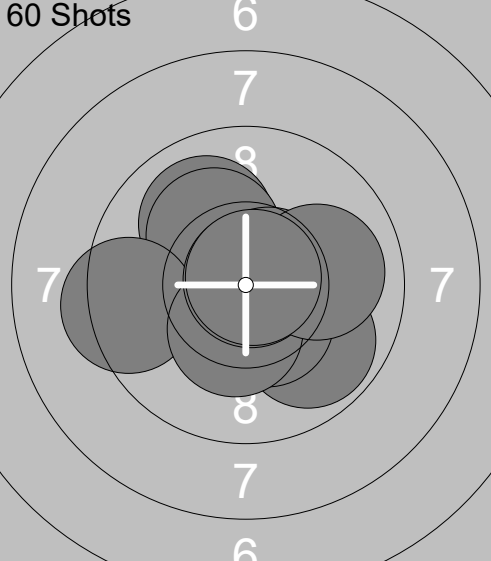
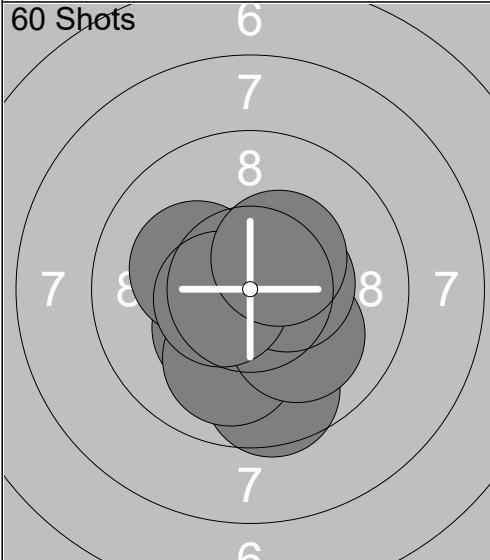
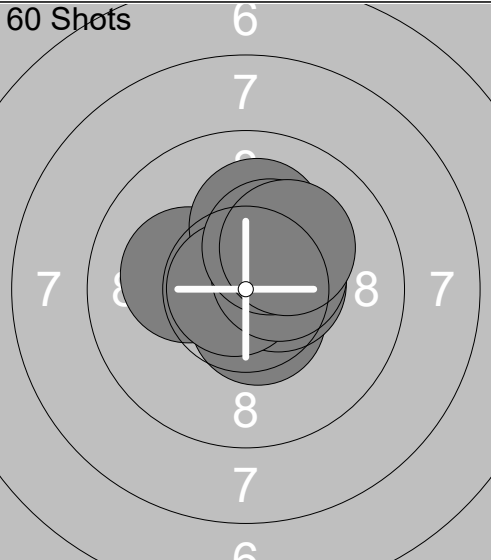
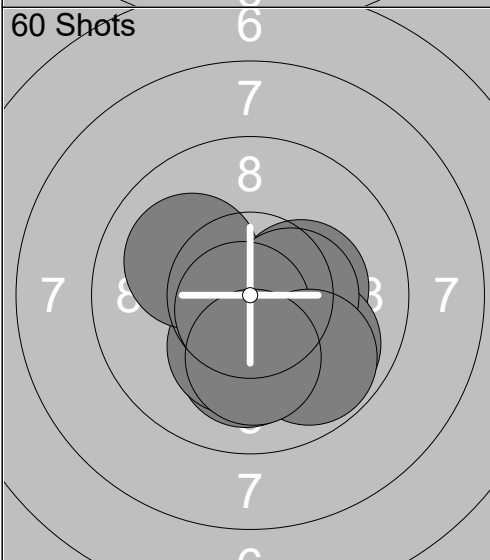
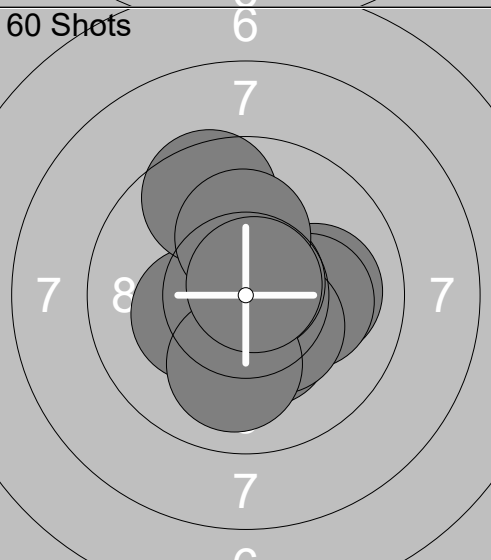
<p>60 Shots</p> 	<p>1: 10.5x ← 2: 10.3x ↗ 3: 10.1 ↓ 4: 10.2x → 5: 8.3 ↓ 6: 10.4x → 7: 9.9 → 8: 9.6 ↓ 9: 10.6x ← 10: 10.7x ↘</p> <p>Series 100.6 100.6</p>	<p>60 Shots</p> 	<p>11: 9.9 ↘ 12: 10.4x ↘ 13: 10.0 ↗ 14: 10.2x ↗ 15: 9.4 ← 16: 10.6x → 17: 10.3x ↓ 18: 10.9x ↗ 19: 10.0 → 20: 10.8x ↗</p> <p>Series 102.5 203.1</p>
<p>60 Shots</p> 	<p>21: 10.3x ↘ 22: 10.6x ← 23: 9.6 ↓ 24: 10.0 ↓ 25: 10.2x ← 26: 10.8x ↓ 27: 10.1 ↓ 28: 10.5x → 29: 10.6x ← 30: 10.4x ↗</p> <p>Series 103.1 306.2</p>	<p>60 Shots</p> 	<p>31: 10.6x → 32: 10.9x ↗ 33: 10.6x ↓ 34: 10.5x → 35: 10.2x ← 36: 10.1 ↑ 37: 10.8x ← 38: 10.5x → 39: 10.3x ↗ 40: 10.2x ↗</p> <p>Series 104.7 410.9</p>
<p>60 Shots</p> 	<p>41: 10.3x → 42: 10.5x → 43: 9.9 ↘ 44: 10.1 ↓ 45: 10.2x ↓ 46: 10.1 ↗ 47: 10.4x → 48: 10.7x ↓ 49: 9.8 ↘ 50: 10.1 ↓</p> <p>Series 102.1 513.0</p>	<p>60 Shots</p> 	<p>51: 10.0 → 52: 10.1 → 53: 10.3x ↓ 54: 10.4x ↘ 55: 10.7x ↗ 56: 10.3x ← 57: 10.0 ↓ 58: 9.6 ↗ 59: 10.2x ↑ 60: 10.8x ↗</p> <p>Series 102.4 615.4</p>

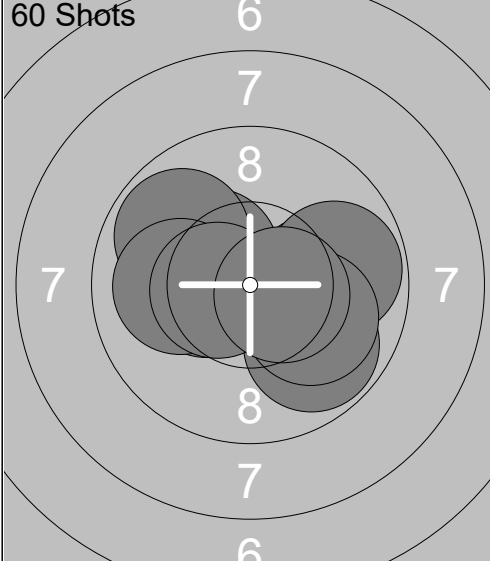
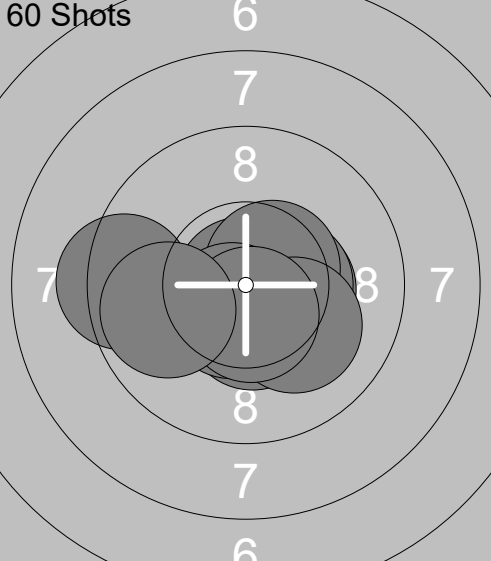
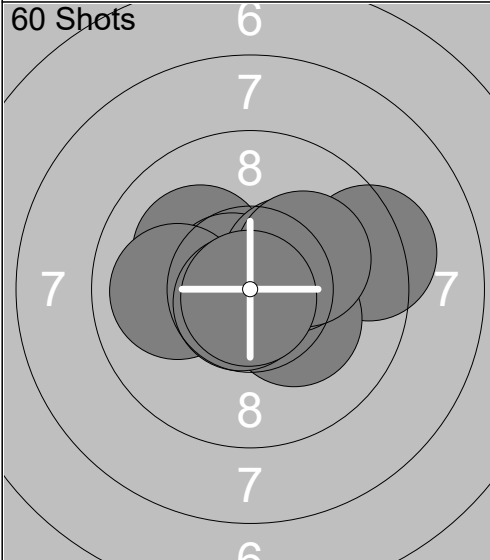
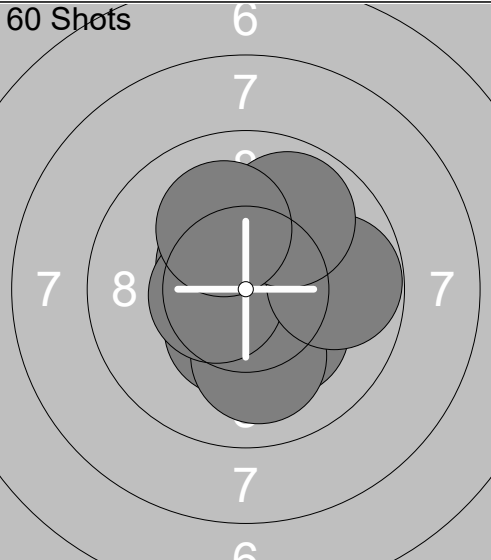
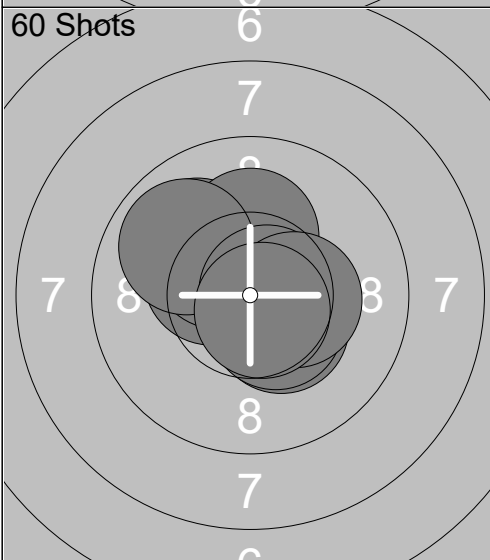
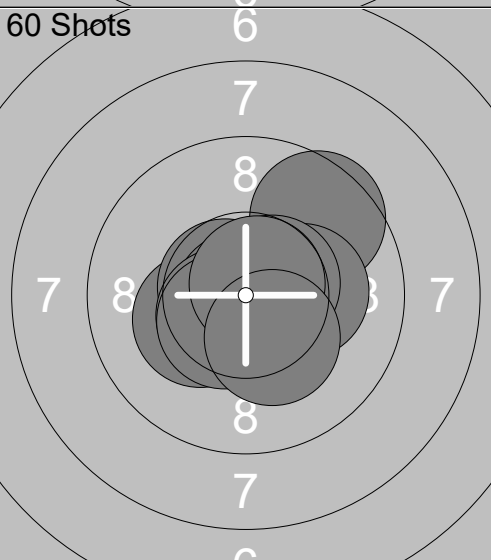
<p>60 Shots</p> 	<p>1: 10.1 → 2: 9.8 → 3: 10.3x ↗ 4: 10.4x ← 5: 9.8 ↘ 6: 9.8 ↗ 7: 10.0 ← 8: 10.5x ← 9: 10.0 ↘ 10: 10.5x →</p> <p>Series 101.2 101.2</p>	<p>60 Shots</p> 	<p>11: 9.3 ← 12: 10.9x ← 13: 10.4x → 14: 10.4x → 15: 10.5x ↗ 16: 10.4x ↓ 17: 10.1 ↘ 18: 10.6x ↓ 19: 10.6x ↓ 20: 9.9 ←</p> <p>Series 103.1 204.3</p>
<p>60 Shots</p> 	<p>21: 9.3 → 22: 10.1 ↗ 23: 10.7x ↖ 24: 10.7x → 25: 10.0 ← 26: 10.3x ↘ 27: 10.3x ↗ 28: 10.7x ↘ 29: 10.1 ↗ 30: 10.8x ↓</p> <p>Series 103.0 307.3</p>	<p>60 Shots</p> 	<p>31: 10.5x ↖ 32: 10.2x ↘ 33: 10.4x ↓ 34: 10.5x ↑ 35: 10.7x ↘ 36: 10.1 ↓ 37: 10.5x ← 38: 9.8 → 39: 9.9 ↗ 40: 10.1 ↑</p> <p>Series 102.7 410.0</p>
<p>60 Shots</p> 	<p>41: 10.4x ↘ 42: 10.0 ↗ 43: 10.4x ↖ 44: 10.5x ↘ 45: 10.3x ↗ 46: 10.2x ↑ 47: 9.9 ↗ 48: 10.7x → 49: 10.4x → 50: 10.7x ↘</p> <p>Series 103.5 513.5</p>	<p>60 Shots</p> 	<p>51: 9.6 ↗ 52: 10.3x ← 53: 10.7x ↖ 54: 10.9x ← 55: 10.2x → 56: 10.5x ← 57: 10.6x → 58: 10.5x ↘ 59: 10.7x ↗ 60: 10.3x ↘</p> <p>Series 104.3 617.8</p>

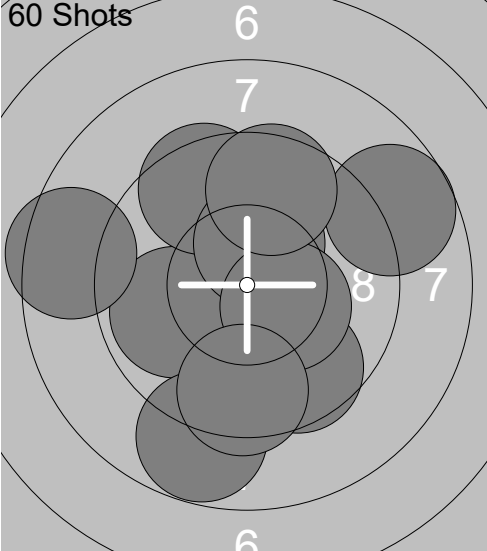
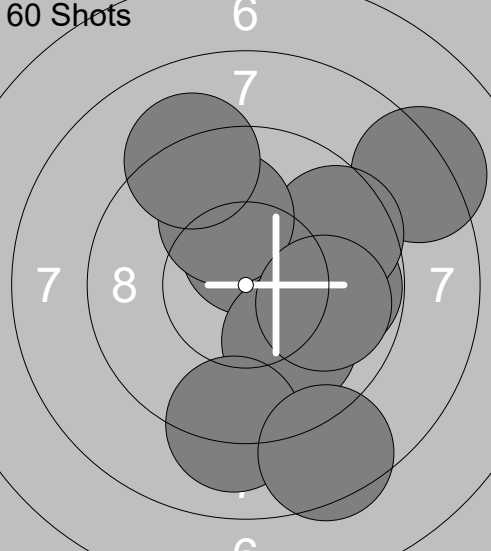
<p>60 Shots</p>  <p style="text-align: center;">6 7 8 7</p>	<p>1: 9.9 ← 2: 9.5 ↗ 3: 10.4x ↗ 4: 8.8 ↓ 5: 9.6 ↓ 6: 8.5 ← 7: 10.3x → 8: 8.7 → 9: 9.5 ↓ 10: 9.6 ↑</p> <p>Series 94.8</p> <p style="text-align: center;">94.8</p>	<p>60 Shots</p>  <p style="text-align: center;">6 7 8 7</p>	<p>11: 9.8 → 12: 8.2 ↗ 13: 10.4x ↗ 14: 10.0 ↓ 15: 9.6 → 16: 9.1 ↓ 17: 10.0 ↑ 18: 9.9 → 19: 8.5 ↓ 20: 9.2 ↑</p> <p>Series 94.7</p> <p style="text-align: center;">189.5</p>
---	--	---	--

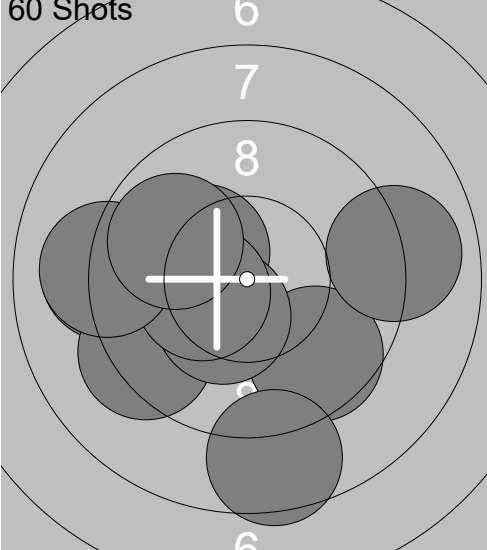
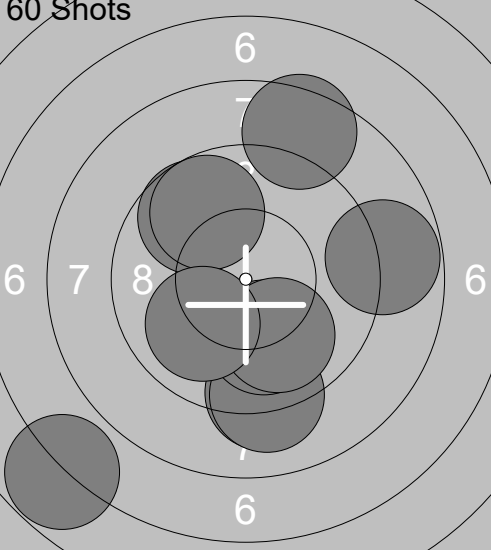
<p>60 Shots</p>  <p style="text-align: center;">6 6 7 8</p>	<p>21: 10.3x ↖ 22: 9.1 ← 23: 9.6 ↓ 24: 9.3 ← 25: 10.4x ↓ 26: 10.3x ← 27: 9.1 ← 28: 9.0 → 29: 9.9 ↖ 30: 8.6 ↓</p> <p>Series 95.6</p> <p style="text-align: center;">285.1</p>	<p>60 Shots</p>  <p style="text-align: center;">6 6 7 8 6</p>	<p>31: 9.2 ↓ 32: 9.7 ↗ 33: 9.7 ↗ 34: 8.5 ↑ 35: 8.8 → 36: 9.1 ↓ 37: 10.0 ↓ 38: 6.8 ↖ 39: 9.9 ↓ 40: 10.0 ↖</p> <p>Series 91.7</p> <p style="text-align: center;">376.8</p>
--	--	--	--

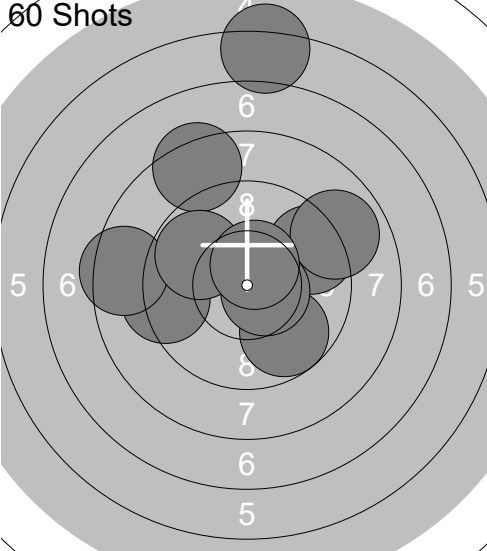
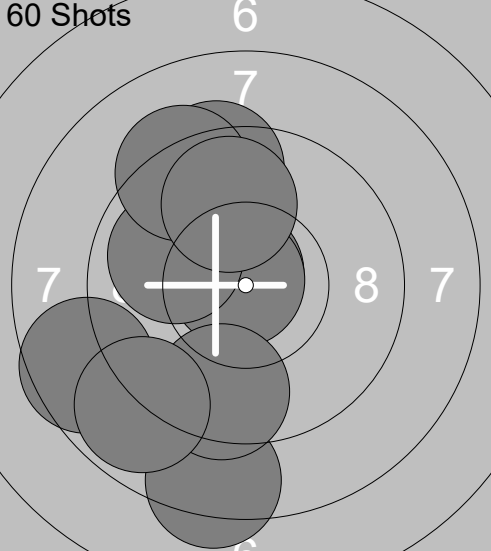
<p>60 Shots</p>  <p style="text-align: center;">6 6 7 8 7 6 5</p>	<p>41: 9.3 ← 42: 9.7 ↓ 43: 6.2 ↑ 44: 9.5 → 45: 8.5 ← 46: 8.4 ↑ 47: 9.8 ↖ 48: 8.9 → 49: 10.6x → 50: 10.5x ↑</p> <p>Series 91.4</p> <p style="text-align: center;">468.2</p>	<p>60 Shots</p>  <p style="text-align: center;">6 6 7 8 7 6</p>	<p>51: 10.7x ↖ 52: 8.6 ← 53: 10.8x ↖ 54: 9.9 ↖ 55: 8.3 ↓ 56: 9.4 ↑ 57: 9.2 ↑ 58: 9.5 ↓ 59: 8.9 ↖ 60: 9.9 ↑</p> <p>Series 95.2</p> <p style="text-align: center;">563.4</p>
---	--	---	--

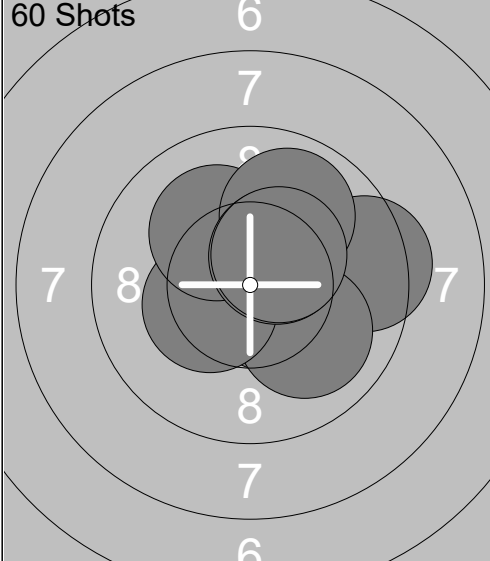
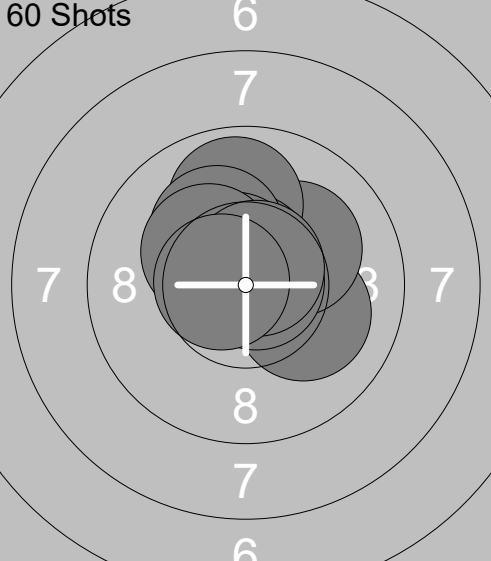
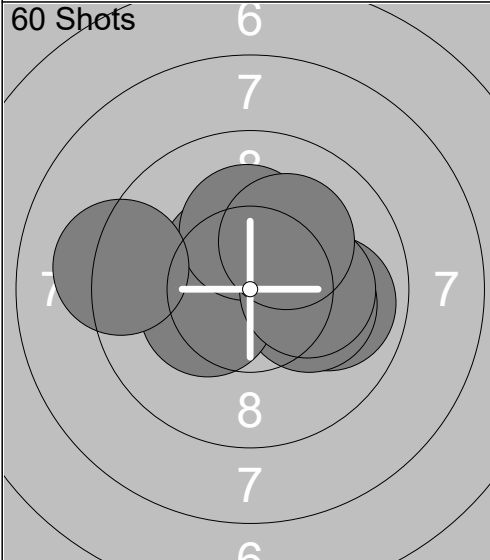
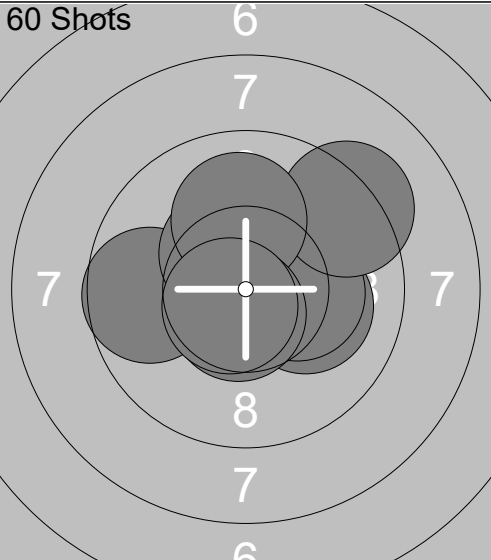
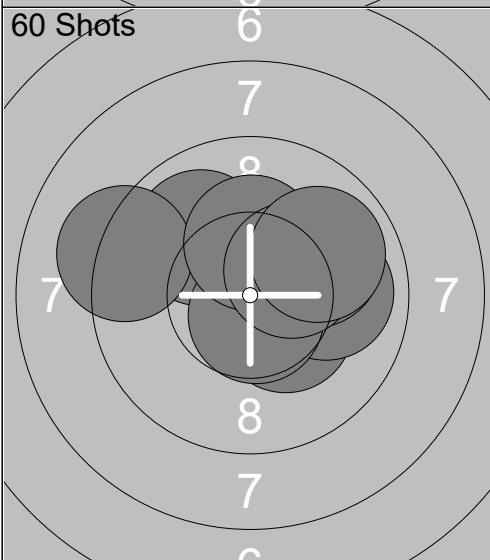
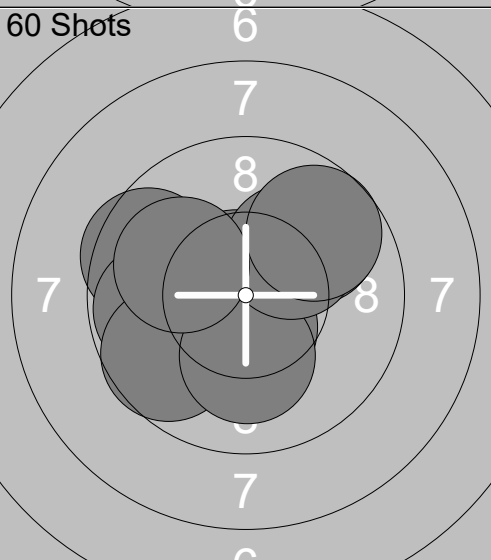
<p>60 Shots</p> 	<p>1: 10.4x ↗ 2: 10.6x ↘ 3: 10.6x → 4: 9.4 → 5: 10.0 ↘ 6: 10.4x ← 7: 10.1 ↗ 8: 9.9 ↗ 9: 10.4x ↗ 10: 10.4x ↗</p> <p>Series 102.2 102.2</p>	<p>60 Shots</p> 	<p>11: 10.1 ⇒ 12: 10.2x ↗ 13: 9.9 ↑ 14: 10.6x ↑ 15: 10.2x ↖ 16: 10.6x ↖ 17: 10.3x ↖ 18: 10.8x → 19: 10.7x ↗ 20: 10.6x ←</p> <p>Series 104.0 206.2</p>
<p>60 Shots</p> 	<p>21: 9.9 → 22: 10.3x ↗ 23: 10.1 → 24: 10.4x ↗ 25: 10.5x ↖ 26: 10.3x ← 27: 10.2x ↑ 28: 9.2 ← 29: 10.2x → 30: 10.2x ↗</p> <p>Series 101.3 307.5</p>	<p>60 Shots</p> 	<p>31: 10.3x ↑ 32: 10.5x ↖ 33: 9.7 ← 34: 10.1 ⇒ 35: 10.4x ↖ 36: 10.3x → 37: 9.2 ↗ 38: 10.0 ↑ 39: 10.6x ↓ 40: 10.6x ↙</p> <p>Series 101.7 409.2</p>
<p>60 Shots</p> 	<p>41: 10.5x ↗ 42: 10.3x ↘ 43: 10.0 ↗ 44: 9.2 ← 45: 9.9 → 46: 10.7x ↓ 47: 10.0 ↗ 48: 10.3x ↑ 49: 10.3x ↗ 50: 9.9 ↗</p> <p>Series 101.1 510.3</p>	<p>60 Shots</p> 	<p>51: 10.5x ↓ 52: 9.8 ↗ 53: 10.7x ↖ 54: 9.6 ← 55: 9.8 ← 56: 9.7 ↙ 57: 10.1 ↓ 58: 10.1 ↗ 59: 10.0 ↖ 60: 9.7 ↗</p> <p>Series 100.0 610.3</p>



<b>Relay</b> <b>5</b>	<b>Lane</b> <b>11</b>	<b>Susan Carter</b>
--------------------------	--------------------------	---------------------

WVU Mobile Range		
------------------	--	--

18.11.2023	Walther Cup 2023	West Virginia University
------------	------------------	--------------------------

Comment	Signature
---------	-----------

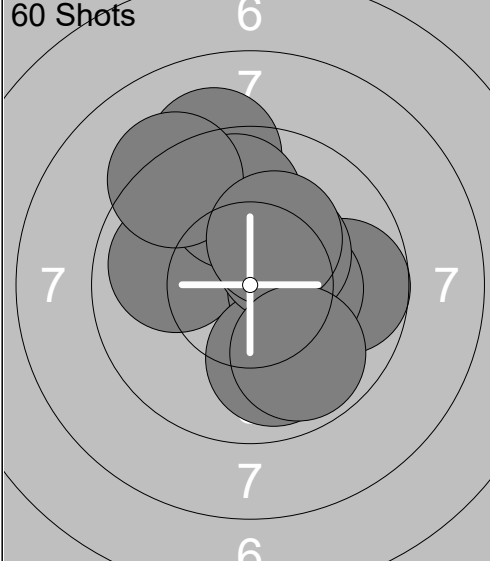
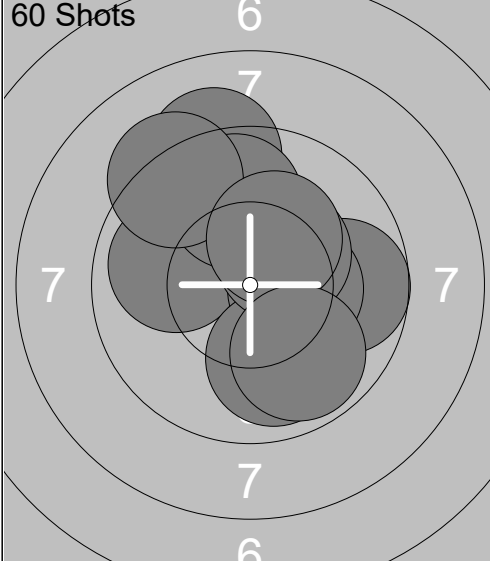
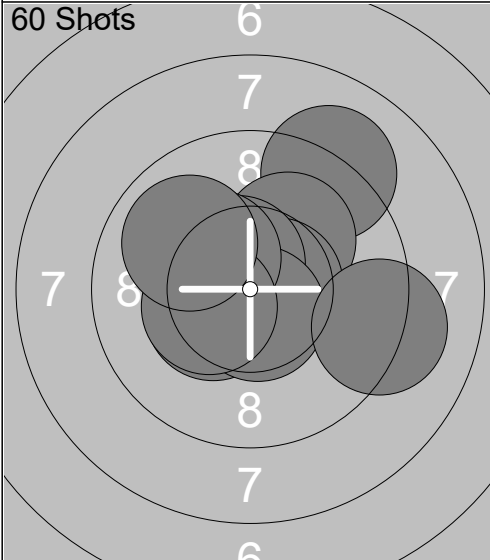
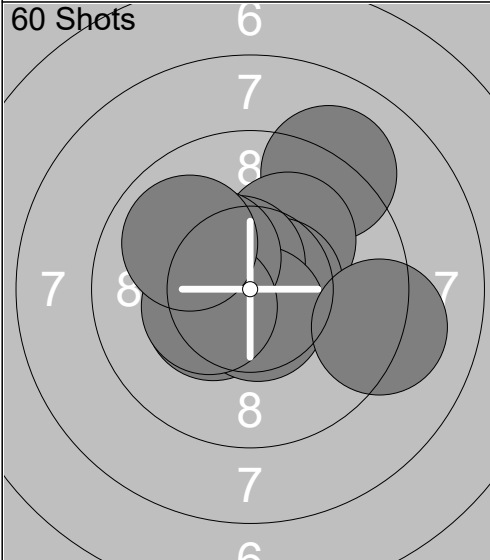
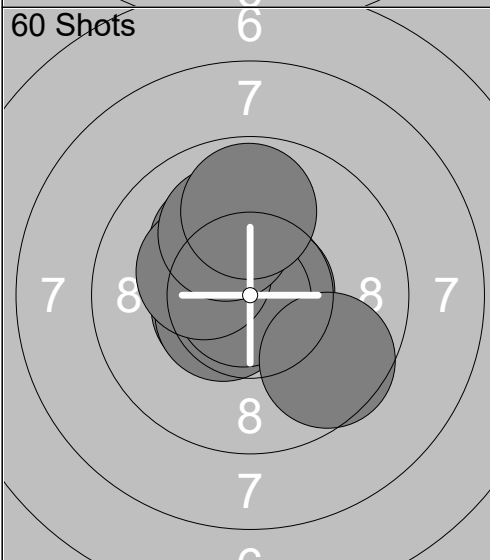
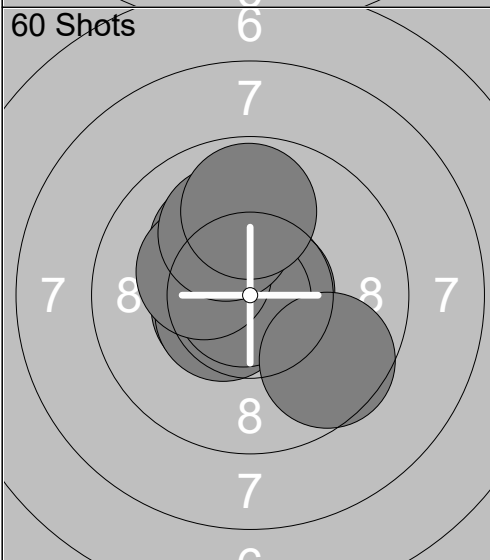
<p>60 Shots</p> 	<p>1: 9.2 ↑ 2: 9.7 → 3: 9.9 ← 4: 10.4x → 5: 9.8 ↑ 6: 9.9 ↓ 7: 9.2 ↗ 8: 10.4x ↗ 9: 10.3x ↗ 10: 9.8 ↓</p> <p>Series 98.6 98.6</p>	<p>60 Shots</p> 	<p>11: 10.3x ← 12: 10.5x ↓ 13: 10.1 ↖ 14: 9.4 ↗ 15: 10.6x ↓ 16: 10.4x → 17: 10.3x → 18: 9.3 ↗ 19: 10.2x ↖ 20: 10.4x ↑</p> <p>Series 101.5 200.1</p>
<p>60 Shots</p> 	<p>21: 9.1 ↗ 22: 10.1 ↗ 23: 10.4x ← 24: 10.6x → 25: 10.6x ↗ 26: 10.6x ↓ 27: 10.3x ↗ 28: 10.4x ← 29: 9.2 → 30: 9.9 ↖</p> <p>Series 101.2 301.3</p>	<p>60 Shots</p> 	<p>31: 10.6x ↑ 32: 10.2x ↗ 33: 10.6x ↗ 34: 10.4x ← 35: 10.6x ↖ 36: 10.4x ← 37: 9.5 ↖ 38: 9.4 ↓ 39: 9.5 → 40: 10.6x →</p> <p>Series 101.8 403.1</p>
<p>60 Shots</p> 	<p>41: 10.7x → 42: 10.2x ↗ 43: 10.5x ← 44: 10.5x ↖ 45: 10.5x ↖ 46: 10.8x ↖ 47: 10.3x ↖ 48: 10.1 ↑ 49: 9.8 ↑ 50: 9.6 ↓</p> <p>Series 103.0 506.1</p>	<p>60 Shots</p> 	<p>51: 9.9 ↑ 52: 10.9x ↖ 53: 10.3x → 54: 10.2x ↗ 55: 10.7x ↗ 56: 10.3x ↖ 57: 10.9x → 58: 9.9 → 59: 9.5 → 60: 9.8 ↗</p> <p>Series 102.4 608.5</p>

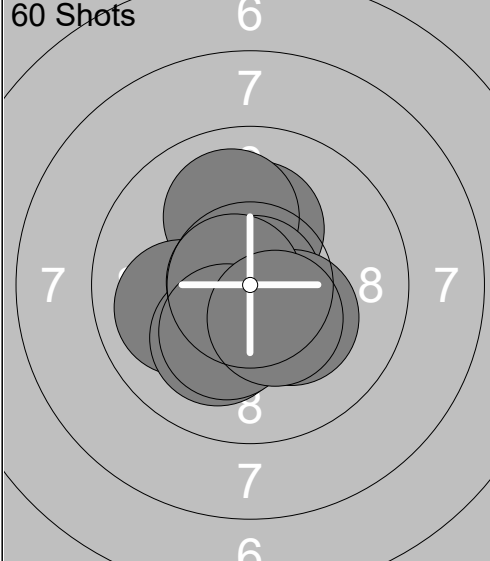
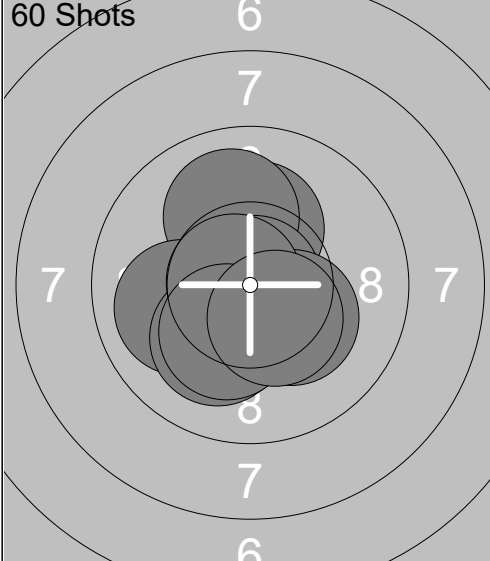
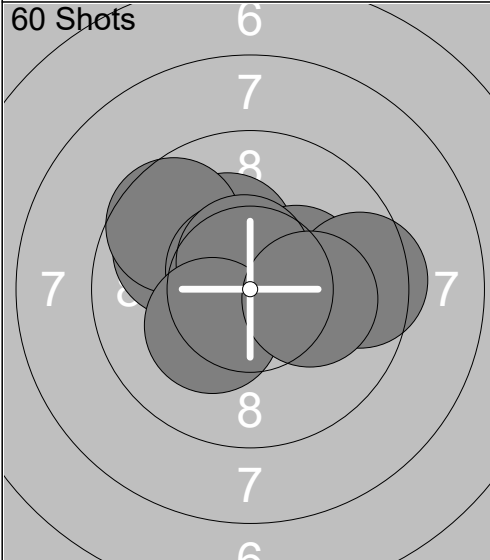
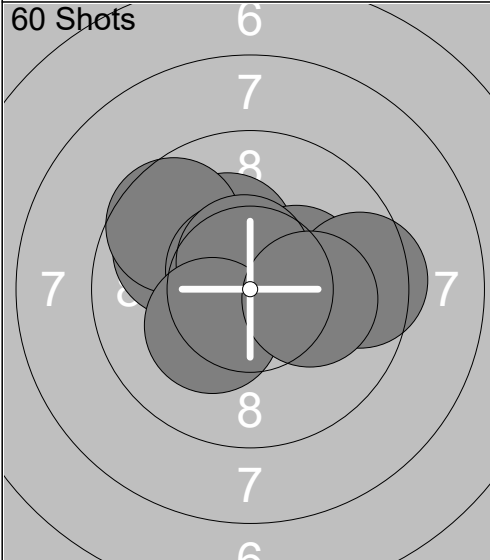
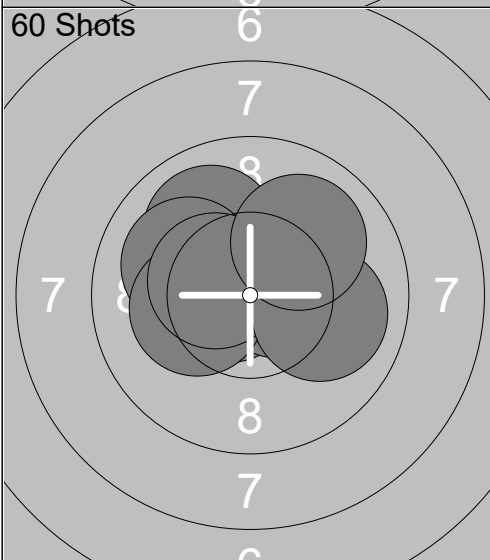
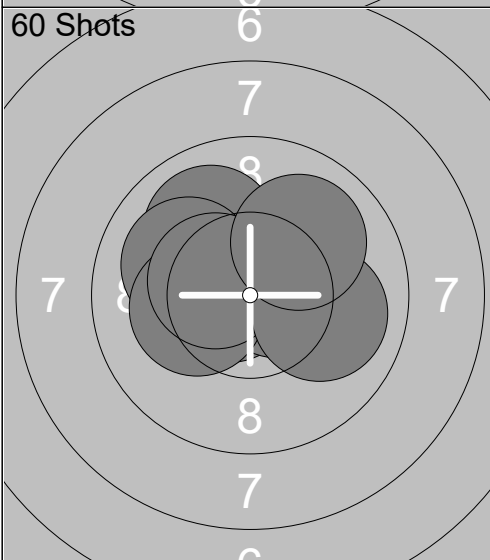
<p>60 Shots</p>  <p style="text-align: center;">6 7 7 8 7</p> <p style="text-align: center;">Series 103.3 103.3</p>	<p>1: 10.2x ↑ 2: 10.0 ↑ 3: 10.4x ↓ 4: 10.0 ← 5: 10.9x → 6: 10.1 ↓ 7: 10.3x ↓ 8: 10.7x ← 9: 10.3x ↓ 10: 10.4x ↓</p> <p style="text-align: center;">Series 103.3 103.3</p>	<p>60 Shots</p>  <p style="text-align: center;">6 7 8 7 7</p> <p style="text-align: center;">Series 102.6 205.9</p>	<p>11: 10.4x → 12: 10.6x ↓ 13: 9.6 ← 14: 10.2x ↓ 15: 9.6 ↓ 16: 10.2x ← 17: 10.8x ↑ 18: 10.2x → 19: 10.5x → 20: 10.5x ←</p> <p style="text-align: center;">Series 102.6 205.9</p>
<p>60 Shots</p>  <p style="text-align: center;">6 6 7 8 7</p> <p style="text-align: center;">Series 102.0 307.9</p>	<p>21: 10.2x ↑ 22: 10.3x → 23: 9.9 ← 24: 9.5 → 25: 10.8x ↑ 26: 9.6 ↗ 27: 10.6x ↗ 28: 10.6x ↑ 29: 10.3x ↓ 30: 10.2x →</p> <p style="text-align: center;">Series 102.0 307.9</p>	<p>60 Shots</p>  <p style="text-align: center;">6 7 8 7 7</p> <p style="text-align: center;">Series 103.5 411.4</p>	<p>31: 9.8 → 32: 10.3x → 33: 10.5x ↓ 34: 10.8x ↗ 35: 10.8x ↑ 36: 9.3 ← 37: 10.7x ↑ 38: 10.3x ← 39: 10.6x ↗ 40: 10.4x ↓</p> <p style="text-align: center;">Series 103.5 411.4</p>
<p>60 Shots</p>  <p style="text-align: center;">6 6 7 8 7</p> <p style="text-align: center;">Series 102.8 514.2</p>	<p>41: 10.7x ← 42: 10.6x → 43: 10.5x ↖ 44: 10.3x ↗ 45: 10.0 ↑ 46: 10.0 ← 47: 10.2x ← 48: 10.5x ← 49: 10.0 → 50: 10.0 ↗</p> <p style="text-align: center;">Series 102.8 514.2</p>	<p>60 Shots</p>  <p style="text-align: center;">6 7 8 7 6</p> <p style="text-align: center;">Series 101.2 615.4</p>	<p>51: 10.1 ↓ 52: 10.6x ← 53: 10.5x ← 54: 9.8 → 55: 10.7x ↓ 56: 9.5 → 57: 10.7x ↑ 58: 9.8 ↗ 59: 9.8 → 60: 9.7 ↑</p> <p style="text-align: center;">Series 101.2 615.4</p>

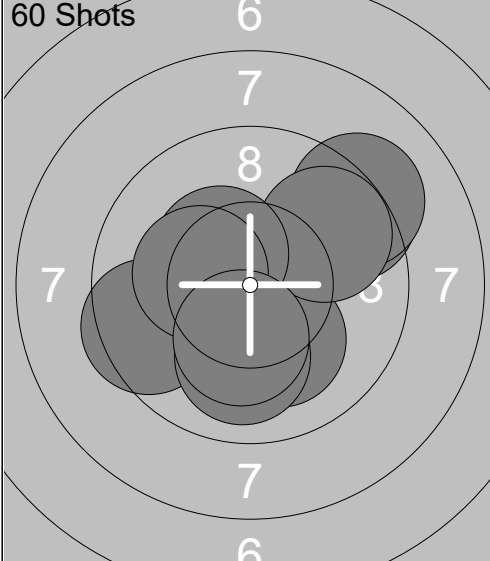
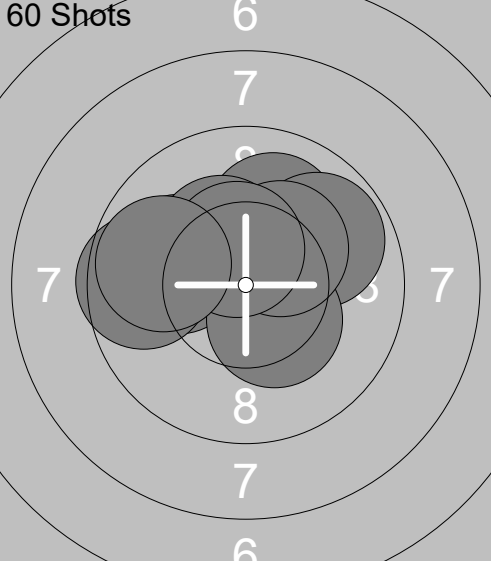
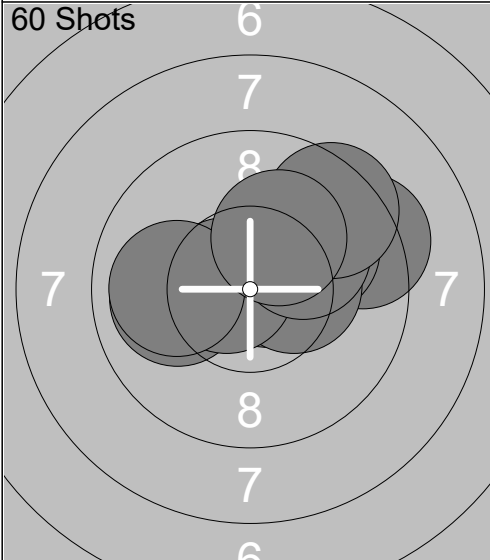
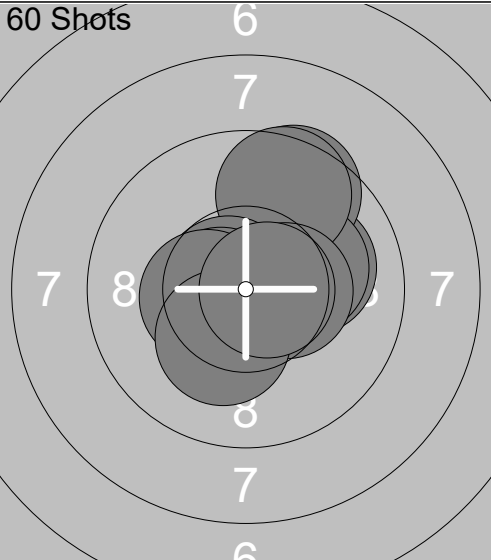
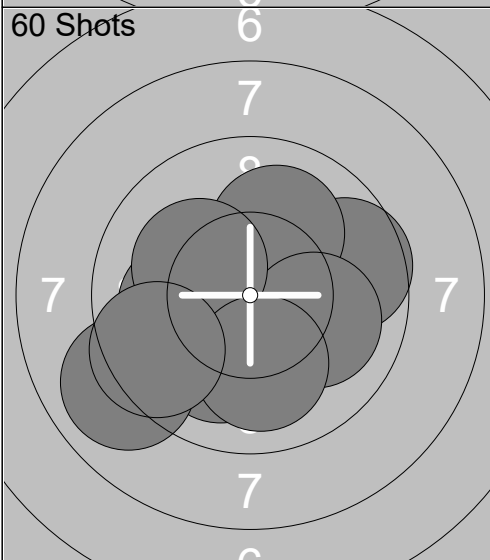
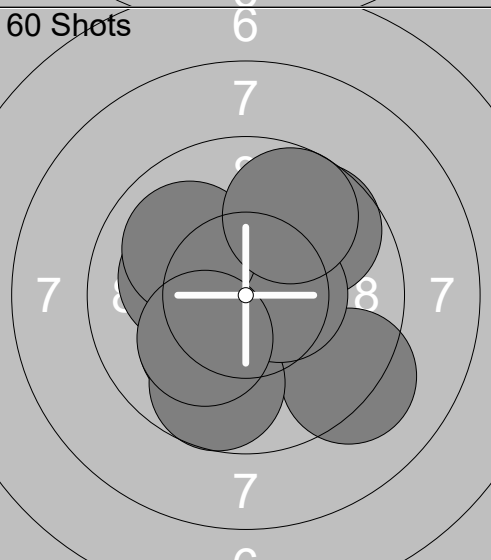
<p>60 Shots</p> 	<p>1: 10.1 ↓ 2: 10.5x ↖ 3: 9.3 ↗ 4: 9.2 ↗ 5: 9.8 ↗ 6: 10.4x ↖ 7: 9.5 ← 8: 10.3x ← 9: 10.0 ↓ 10: 10.2x ↓</p> <p>Series 99.3 99.3</p>	<p>60 Shots</p> 	<p>11: 10.0 ↑ 12: 9.8 ↗ 13: 10.0 ← 14: 10.0 ← 15: 9.6 ← 16: 10.4x ↓ 17: 10.3x ↖ 18: 10.3x ↗ 19: 10.5x ↑ 20: 9.8 ←</p> <p>Series 100.7 200.0</p>
<p>60 Shots</p> 	<p>21: 10.0 ← 22: 9.3 ↗ 23: 10.0 ↗ 24: 10.7x ↗ 25: 10.4x → 26: 10.6x ← 27: 10.1 ↗ 28: 10.0 ← 29: 9.5 ↗ 30: 10.2x ↗</p> <p>Series 100.8 300.8</p>	<p>60 Shots</p> 	<p>31: 10.1 ↗ 32: 9.5 ↑ 33: 10.2x ↗ 34: 9.6 ↑ 35: 10.7x ← 36: 10.4x → 37: 10.6x ← 38: 10.4x ← 39: 10.2x ↓ 40: 10.7x →</p> <p>Series 102.4 403.2</p>
<p>60 Shots</p> 	<p>41: 10.5x ↑ 42: 9.6 → 43: 10.1 ↑ 44: 10.0 → 45: 10.1 ↓ 46: 9.0 ← 47: 10.1 ← 48: 10.2x ↖ 49: 10.0 ↓ 50: 9.5 ←</p> <p>Series 99.1 502.3</p>	<p>60 Shots</p> 	<p>51: 9.7 ↗ 52: 10.1 ← 53: 10.1 ↓ 54: 9.2 ↓ 55: 10.4x ↖ 56: 9.7 ↓ 57: 10.5x → 58: 10.0 ↖ 59: 9.7 ↑ 60: 10.2x ↖</p> <p>Series 99.6 601.9</p>

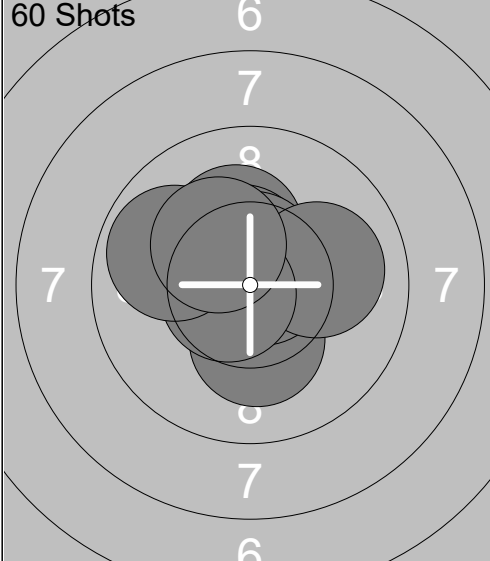
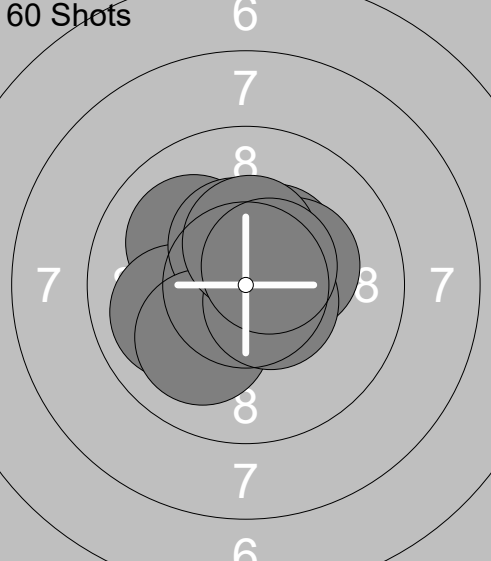
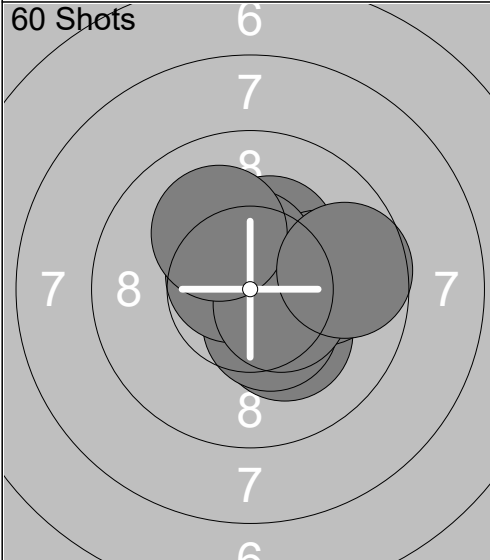
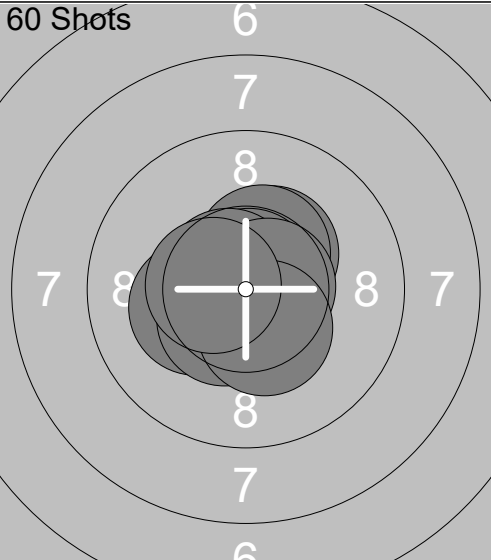
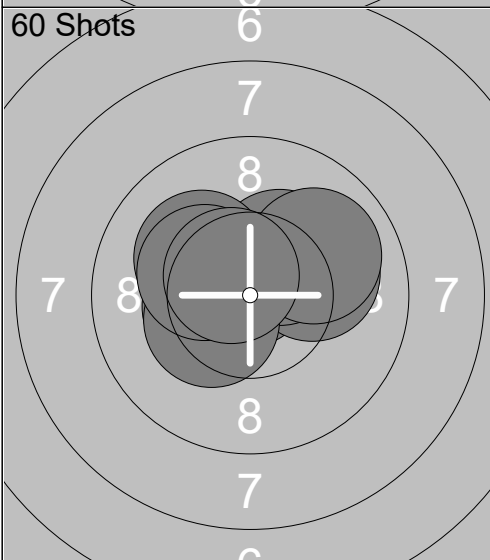
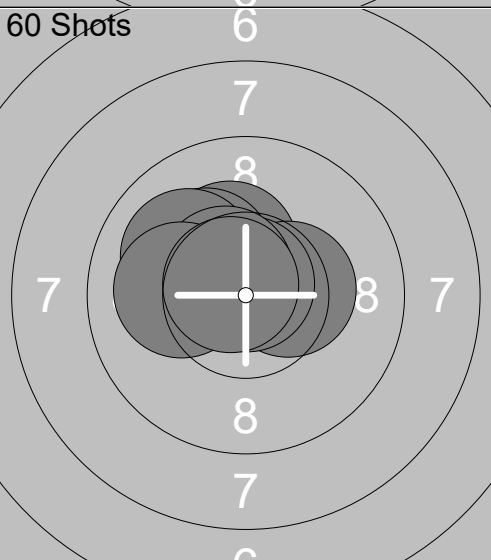
<p>60 Shots</p> 	<p>1: 10.4x ↘ 2: 10.2x ↑ 3: 10.5x ↑ 4: 10.2x ↓ 5: 10.8x ↗ 6: 10.6x ↑ 7: 10.0 → 8: 10.6x ← 9: 9.9 ↙ 10: 10.3x ↖</p> <p>Series 103.5 103.5</p>	<p>60 Shots</p> 	<p>11: 10.5x ↗ 12: 10.4x ↗ 13: 10.1 ↙ 14: 10.0 ← 15: 10.4x ↑ 16: 10.3x → 17: 10.1 ↙ 18: 10.6x ↘ 19: 10.4x ↑ 20: 10.5x ↗</p> <p>Series 103.3 206.8</p>
<p>60 Shots</p> 	<p>21: 10.3x ↑ 22: 10.7x ↗ 23: 10.2x ↘ 24: 10.0 → 25: 10.4x ↘ 26: 10.5x ↑ 27: 10.7x ↖ 28: 10.5x ↘ 29: 10.1 ↑ 30: 9.7 →</p> <p>Series 103.1 309.9</p>	<p>60 Shots</p> 	<p>31: 10.4x ↗ 32: 10.7x ↙ 33: 10.4x ↑ 34: 10.8x ↑ 35: 10.7x ↙ 36: 10.7x → 37: 10.3x ← 38: 10.5x ↙ 39: 10.4x ↘ 40: 10.5x ←</p> <p>Series 105.4 415.3</p>
<p>60 Shots</p> 	<p>41: 10.5x ↑ 42: 10.7x ↑ 43: 10.4x ← 44: 10.1 → 45: 10.3x ↗ 46: 10.3x ← 47: 10.1 ↙ 48: 10.3x ↙ 49: 10.0 ↗ 50: 10.6x ↖</p> <p>Series 103.3 518.6</p>	<p>60 Shots</p> 	<p>51: 10.3x ↑ 52: 10.4x ↙ 53: 10.4x → 54: 10.4x ↙ 55: 10.8x ↑ 56: 10.2x ↙ 57: 10.0 ↙ 58: 10.6x ↙ 59: 10.1 ← 60: 10.7x ↙</p> <p>Series 103.9 622.5</p>

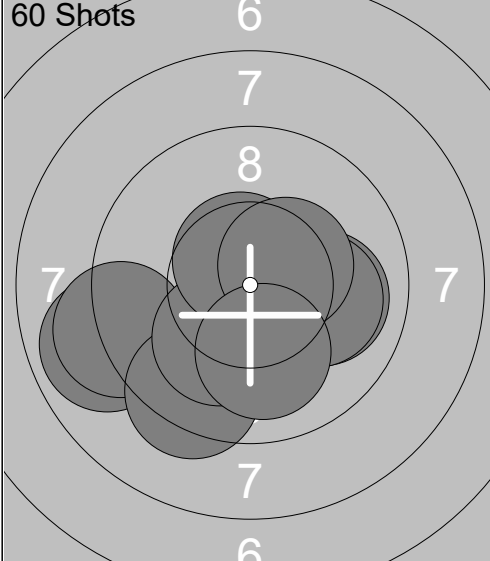
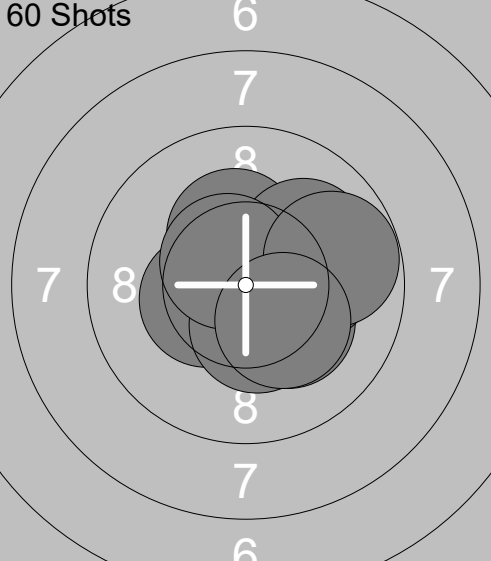
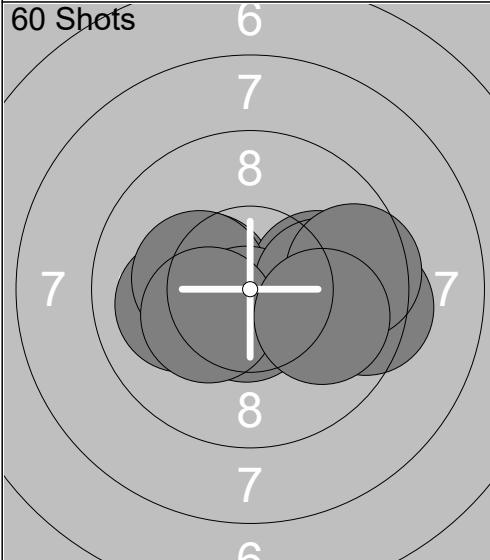
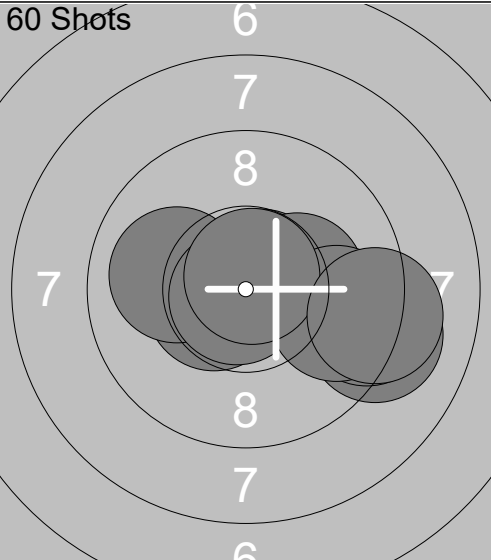
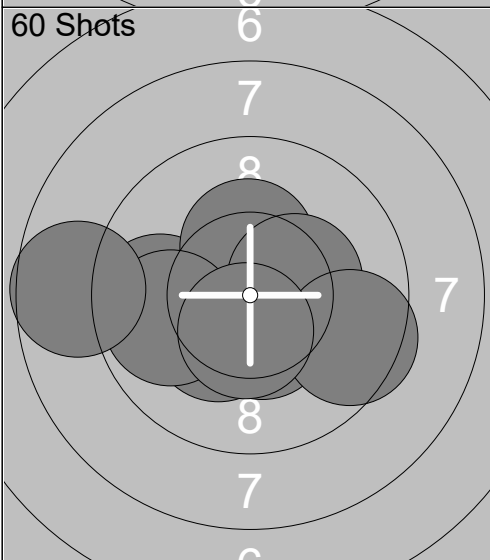
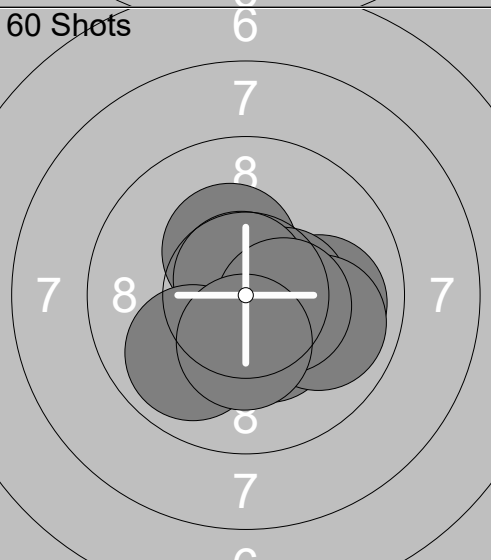
<p>60 Shots</p> 	<p>1: 10.8x ↓ 2: 10.0 → 3: 10.1 → 4: 8.9 ← 5: 9.1 ← 6: 9.4 ↓ 7: 10.1 ↓ 8: 10.6x ↑ 9: 10.4x ↗ 10: 10.0 ↓</p> <p>Series 99.4 99.4</p>	<p>60 Shots</p> 	<p>11: 10.4x ← 12: 10.5x → 13: 10.4x ↓ 14: 10.3x ↑ 15: 10.2x ↓ 16: 10.1 → 17: 10.0 ↗ 18: 10.6x ↗ 19: 9.8 → 20: 10.3x ↓</p> <p>Series 102.6 202.0</p>
<p>60 Shots</p> 	<p>21: 10.4x ← 22: 10.0 ← 23: 9.4 → 24: 10.1 → 25: 10.3x ← 26: 10.6x ↓ 27: 10.0 → 28: 9.6 → 29: 10.3x ← 30: 9.9 →</p> <p>Series 100.6 302.6</p>	<p>60 Shots</p> 	<p>31: 10.5x ← 32: 10.0 ← 33: 10.7x ↗ 34: 9.1 → 35: 10.3x → 36: 10.8x ← 37: 9.3 → 38: 9.7 → 39: 10.8x ↑ 40: 9.2 →</p> <p>Series 100.4 403.0</p>
<p>60 Shots</p> 	<p>41: 9.8 ← 42: 10.4x ↓ 43: 10.3x ↓ 44: 10.7x ↖ 45: 10.3x ↑ 46: 10.3x → 47: 9.5 → 48: 9.9 ← 49: 8.7 ← 50: 10.5x ↓</p> <p>Series 100.4 503.4</p>	<p>60 Shots</p> 	<p>51: 10.3x ↑ 52: 10.0 → 53: 10.5x → 54: 10.5x ↓ 55: 10.7x ↑ 56: 10.4x ↓ 57: 9.9 → 58: 10.4x → 59: 9.9 ↓ 60: 10.3x ↓</p> <p>Series 102.9 606.3</p>

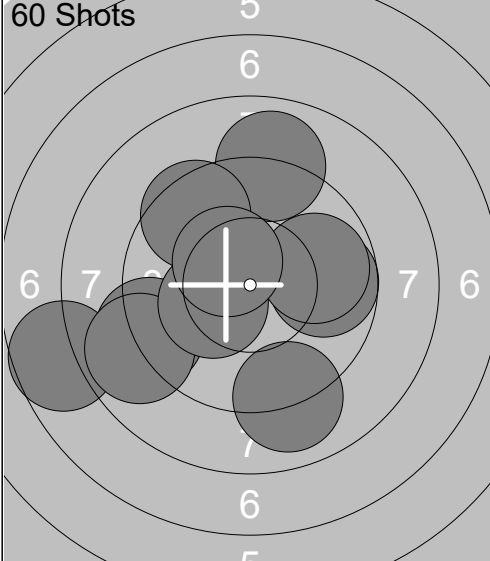
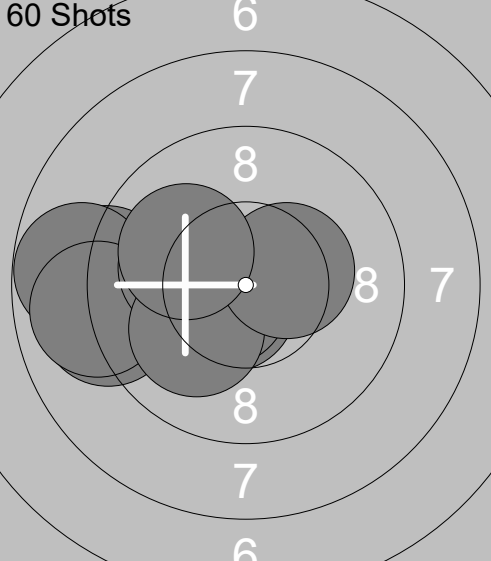
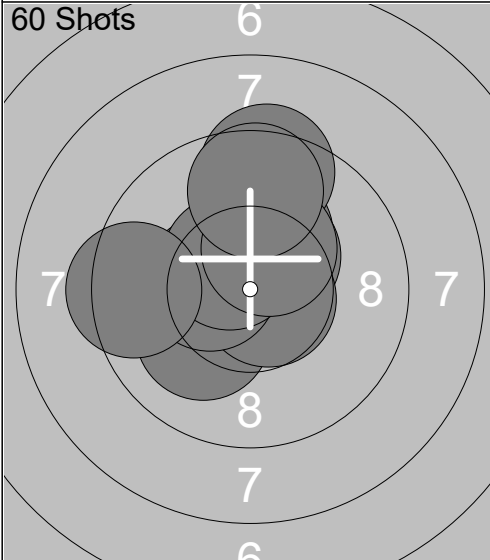
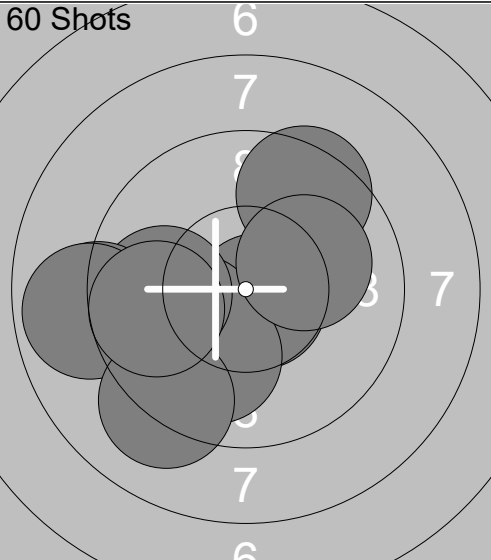
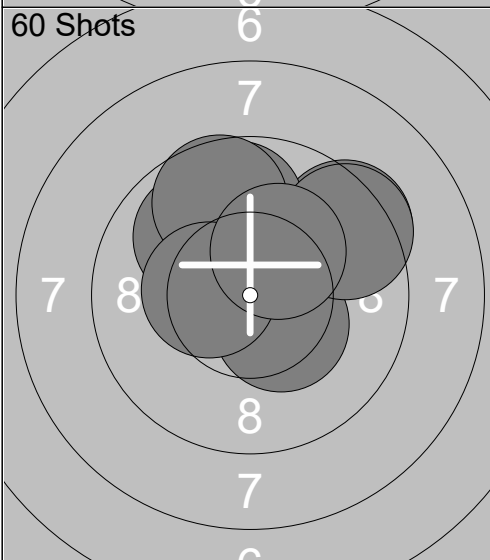
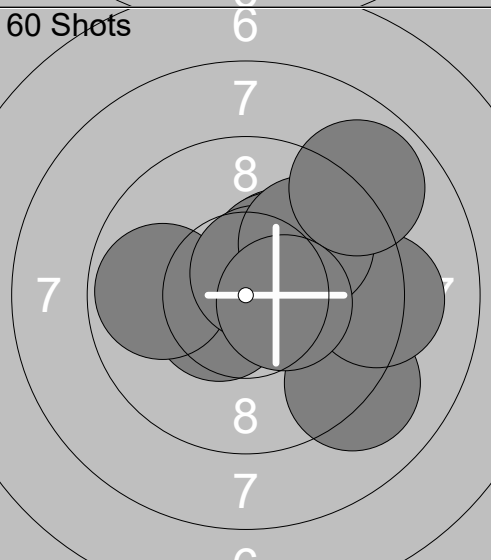
<p>60 Shots</p>  <p style="text-align: center;">6 7 7 6</p>	<p>1: 9.8 →</p> <p>2: 7.7 ←</p> <p>3: 9.9 →</p> <p>4: 9.1 ←</p> <p>5: 8.9 ←</p> <p>6: 9.0 ↓</p> <p>7: 9.0 ↑</p> <p>8: 10.3x ←</p> <p>9: 9.5 ↗</p> <p>10: 10.4x ↖</p> <hr/> <p>Series 93.6</p> <hr/> <p style="text-align: center;">93.6</p>	<p>60 Shots</p>  <p style="text-align: center;">6 7 8 7</p>	<p>11: 9.1 ←</p> <p>12: 10.6x ↙</p> <p>13: 9.1 ←</p> <p>14: 8.8 ←</p> <p>15: 10.6x ↙</p> <p>16: 9.0 ←</p> <p>17: 10.1 ←</p> <p>18: 10.1 ↙</p> <p>19: 10.4x →</p> <p>20: 10.0 ↖</p> <hr/> <p>Series 97.8</p> <hr/> <p style="text-align: center;">191.4</p>
<p>60 Shots</p>  <p style="text-align: center;">6 7 8 7</p>	<p>21: 10.2x ↑</p> <p>22: 10.1 ↙</p> <p>23: 10.4x ↗</p> <p>24: 10.7x ➤</p> <p>25: 10.4x ←</p> <p>26: 10.5x ↖</p> <p>27: 9.4 ↑</p> <p>28: 9.4 ←</p> <p>29: 10.4x ↗</p> <p>30: 9.6 ↑</p> <hr/> <p>Series 101.1</p> <hr/> <p style="text-align: center;">292.5</p>	<p>60 Shots</p>  <p style="text-align: center;">6 7 7 7</p>	<p>31: 10.7x ➤</p> <p>32: 10.1 ↙</p> <p>33: 10.0 ↓</p> <p>34: 9.9 ←</p> <p>35: 9.5 ↗</p> <p>36: 9.0 ←</p> <p>37: 8.9 ←</p> <p>38: 9.1 ↙</p> <p>39: 9.7 ←</p> <p>40: 10.1 ➤</p> <hr/> <p>Series 97.0</p> <hr/> <p style="text-align: center;">389.5</p>
<p>60 Shots</p>  <p style="text-align: center;">6 7 8 7 6</p>	<p>41: 10.4x ➤</p> <p>42: 10.0 ↑</p> <p>43: 9.4 ➤</p> <p>44: 9.9 ↑</p> <p>45: 9.8 ↑</p> <p>46: 9.9 ↖</p> <p>47: 9.7 ↑</p> <p>48: 9.4 ➤</p> <p>49: 10.4x ←</p> <p>50: 10.3x ↗</p> <hr/> <p>Series 99.2</p> <hr/> <p style="text-align: center;">488.7</p>	<p>60 Shots</p>  <p style="text-align: center;">6 7 8 7 6</p>	<p>51: 10.5x ↙</p> <p>52: 10.3x ↗</p> <p>53: 10.3x ↗</p> <p>54: 9.1 ➤</p> <p>55: 9.8 ←</p> <p>56: 10.6x ↗</p> <p>57: 9.2 ➤</p> <p>58: 9.9 ↗</p> <p>59: 8.9 ↗</p> <p>60: 10.4x ➤</p> <hr/> <p>Series 99.0</p> <hr/> <p style="text-align: center;">587.7</p>

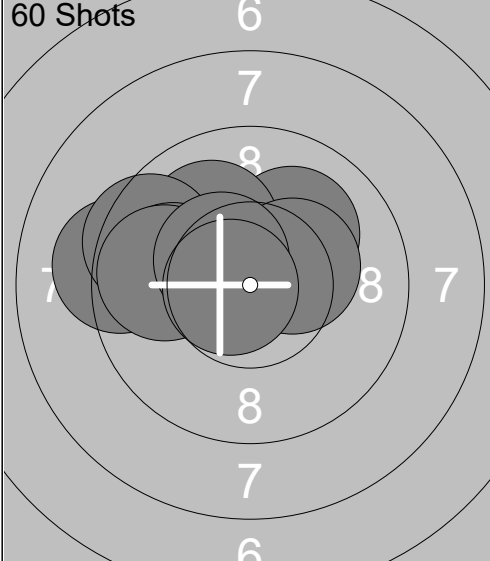
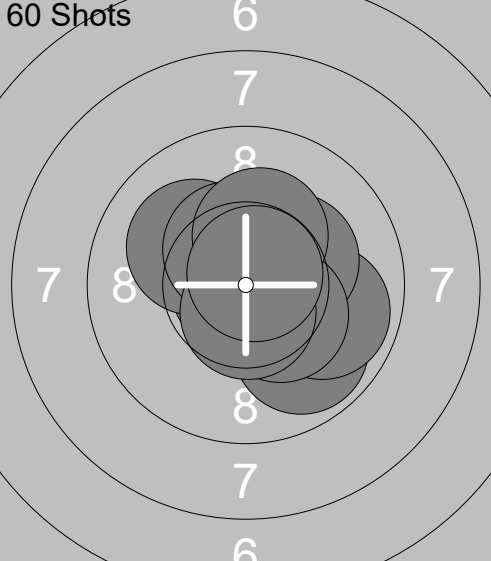
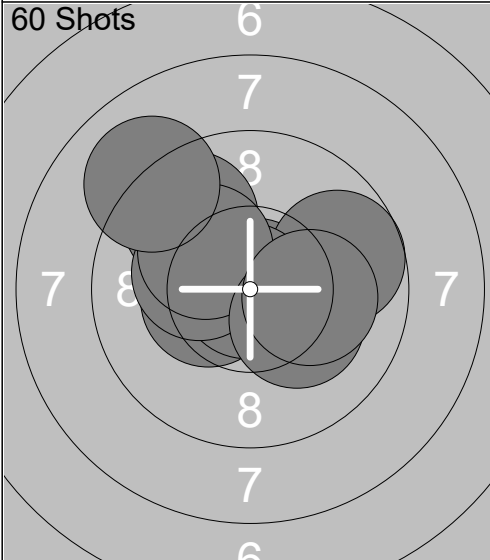
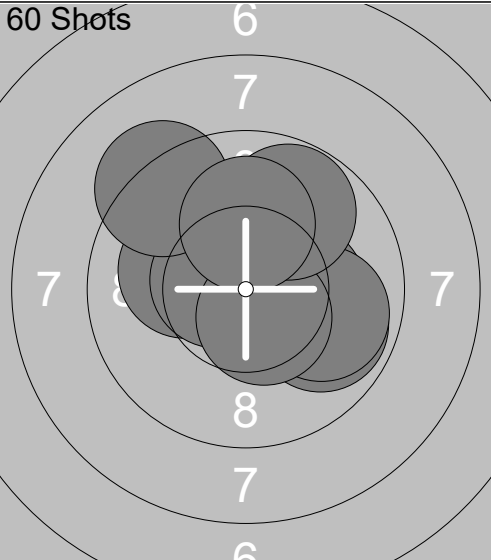
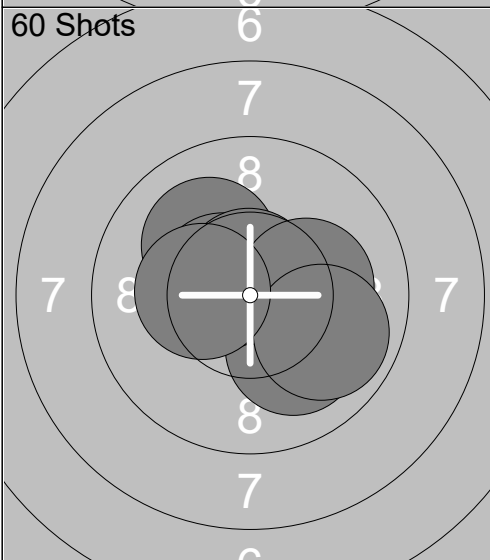
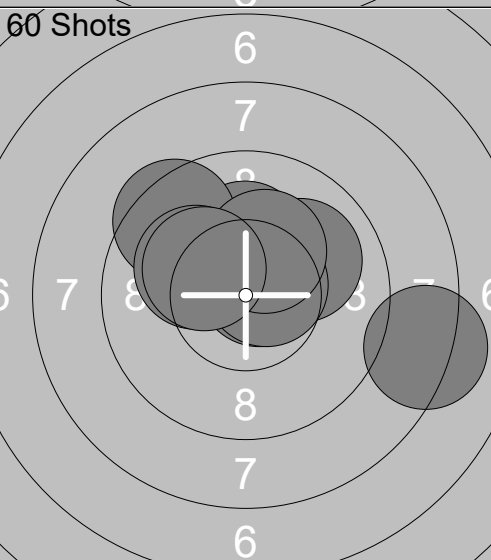
<p>60 Shots</p> 	<p>1: 9.2 ← 2: 10.1 ↗ 3: 10.4x ↖ 4: 10.0 ↗ 5: 9.5 ↖ 6: 9.9 ← 7: 9.8 ← 8: 10.3x → 9: 10.4x ↖ 10: 10.7x ←</p> <p>Series 100.3 100.3</p>	<p>60 Shots</p> 	<p>11: 10.9x ← 12: 9.9 ↘ 13: 9.9 → 14: 10.1 ↖ 15: 10.3x → 16: 10.4x ↗ 17: 10.3x ↘ 18: 10.6x ↓ 19: 10.3x ↗ 20: 10.8x ↗</p> <p>Series 103.5 203.8</p>
<p>60 Shots</p> 	<p>21: 10.9x ↗ 22: 10.4x ← 23: 9.7 → 24: 10.9x ← 25: 9.7 ↗ 26: 10.2x ← 27: 10.2x ↗ 28: 10.2x ↘ 29: 10.2x → 30: 9.0 ↗</p> <p>Series 101.4 305.2</p>	<p>60 Shots</p> 	<p>31: 10.3x → 32: 9.9 → 33: 10.3x ↖ 34: 10.1 ← 35: 9.9 → 36: 10.6x ← 37: 10.5x ↘ 38: 9.8 ↗ 39: 9.2 ↖ 40: 10.1 ↑</p> <p>Series 100.7 405.9</p>
<p>60 Shots</p> 	<p>41: 10.3x ↘ 42: 10.6x ↖ 43: 10.2x ↘ 44: 10.1 ↘ 45: 10.1 ↗ 46: 10.5x ↖ 47: 10.7x ↑ 48: 10.2x → 49: 9.9 ↘ 50: 10.3x ←</p> <p>Series 102.9 508.8</p>	<p>60 Shots</p> 	<p>51: 10.2x ↑ 52: 10.4x ↖ 53: 10.7x ↗ 54: 9.5 ↖ 55: 10.0 → 56: 10.1 ← 57: 10.6x → 58: 8.2 → 59: 10.3x ↗ 60: 10.2x ↖</p> <p>Series 100.2 609.0</p>

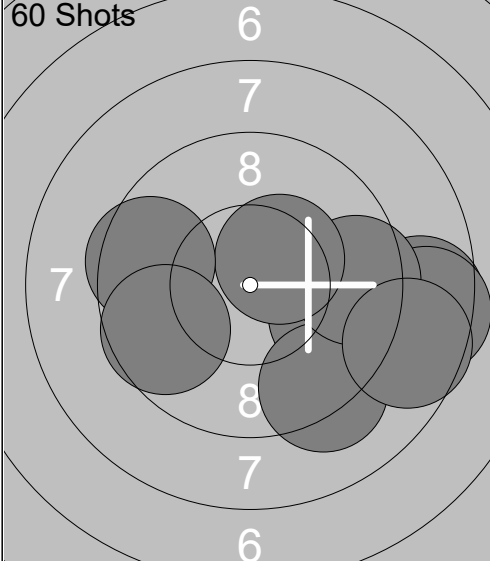
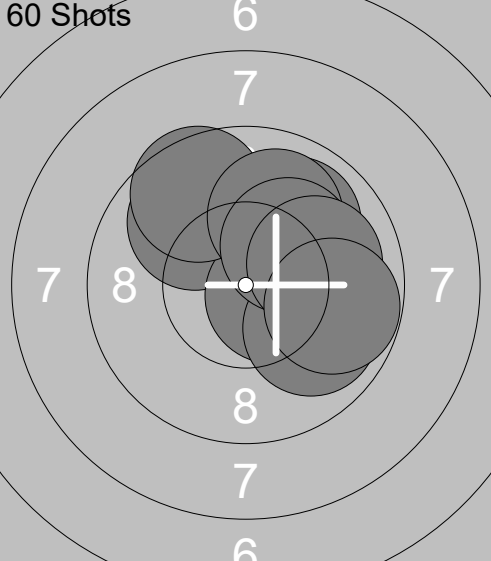
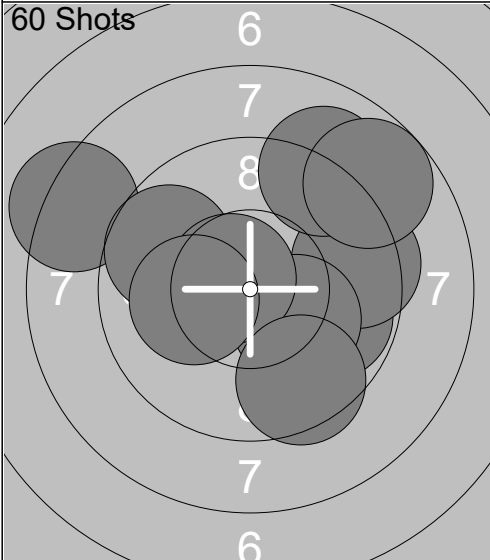
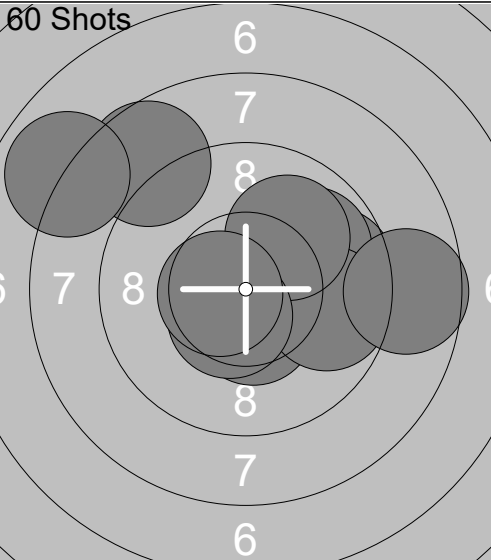
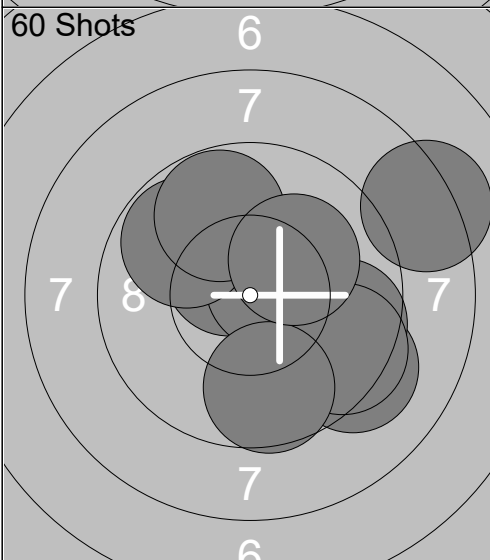
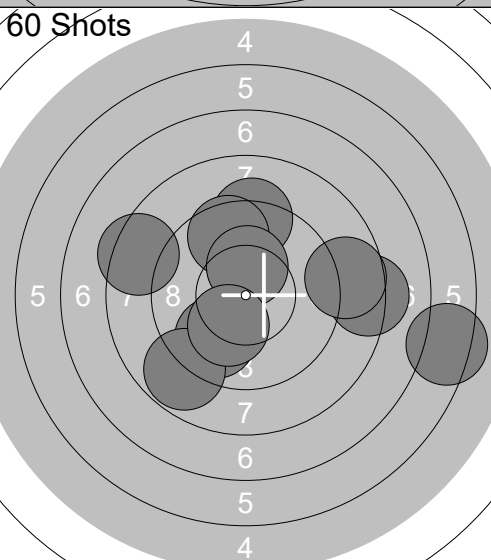
<p>60 Shots</p> 	<p>1: 8.6 →</p> <p>2: 9.7 →</p> <p>3: 9.0 →</p> <p>4: 9.2 ↓</p> <p>5: 8.5 →</p> <p>6: 9.5 →</p> <p>7: 10.4x ↗</p> <p>8: 9.5 ←</p> <p>9: 9.6 ←</p> <p>10: 8.6 →</p> <hr/> <p>Series 92.6</p> <hr/> <p>92.6</p>	<p>60 Shots</p> 	<p>11: 9.9 ↗</p> <p>12: 10.6x →</p> <p>13: 9.9 ↗</p> <p>14: 9.6 ↗</p> <p>15: 9.9 →</p> <p>16: 10.0 ↗</p> <p>17: 9.9 →</p> <p>18: 10.2x ↗</p> <p>19: 10.0 →</p> <p>20: 9.8 →</p> <hr/> <p>Series 99.8</p> <hr/> <p>192.4</p>
<p>60 Shots</p> 	<p>21: 9.8 →</p> <p>22: 9.4 →</p> <p>23: 8.3 ↖</p> <p>24: 9.0 ↗</p> <p>25: 9.7 ↖</p> <p>26: 8.8 ↗</p> <p>27: 10.2x →</p> <p>28: 10.6x ↖</p> <p>29: 9.5 ↓</p> <p>30: 10.2x ←</p> <hr/> <p>Series 95.5</p> <hr/> <p>287.9</p>	<p>60 Shots</p> 	<p>31: 9.7 →</p> <p>32: 10.5x ↓</p> <p>33: 9.9 ↗</p> <p>34: 9.8 →</p> <p>35: 10.0 ↗</p> <p>36: 8.7 ↖</p> <p>37: 10.5x ↓</p> <p>38: 7.9 ↖</p> <p>39: 8.7 →</p> <p>40: 10.6x ←</p> <hr/> <p>Series 96.3</p> <hr/> <p>384.2</p>
<p>60 Shots</p> 	<p>41: 9.2 ↓</p> <p>42: 8.2 →</p> <p>43: 10.5x ↗</p> <p>44: 10.6x →</p> <p>45: 9.6 →</p> <p>46: 9.5 ↓</p> <p>47: 9.8 ↗</p> <p>48: 9.8 ↗</p> <p>49: 9.7 ↓</p> <p>50: 10.2x ↗</p> <hr/> <p>Series 97.1</p> <hr/> <p>481.3</p>	<p>60 Shots</p> 	<p>51: 9.8 ↖</p> <p>52: 9.3 ↗</p> <p>53: 9.6 ↗</p> <p>54: 8.2 →</p> <p>55: 10.3x ↗</p> <p>56: 8.8 ↖</p> <p>57: 8.7 →</p> <p>58: 10.2x ↓</p> <p>59: 8.4 ←</p> <p>60: 6.4 →</p> <hr/> <p>Series 89.7</p> <hr/> <p>571.0</p>

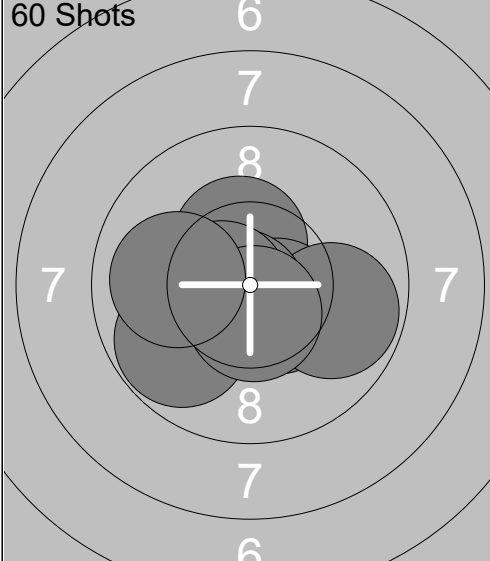
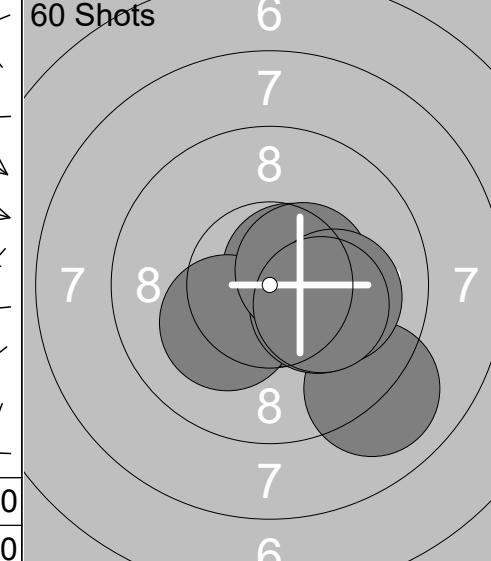
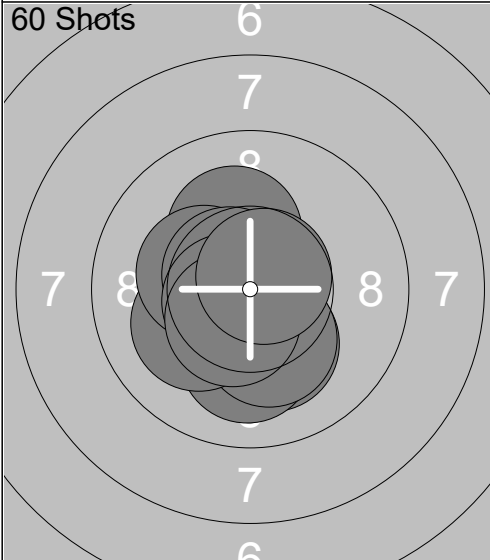
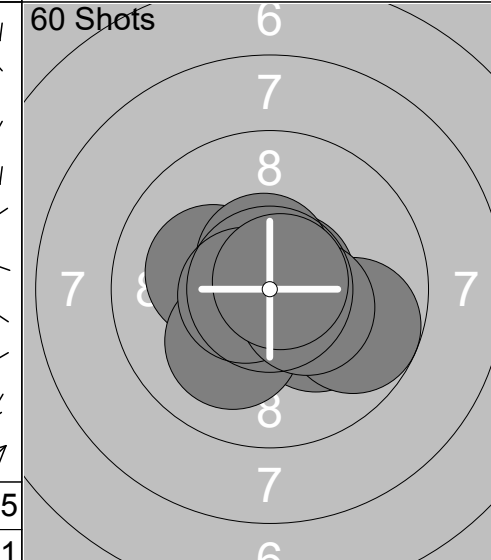
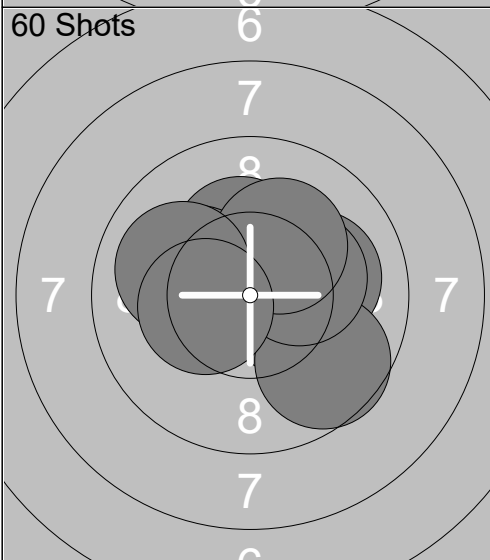
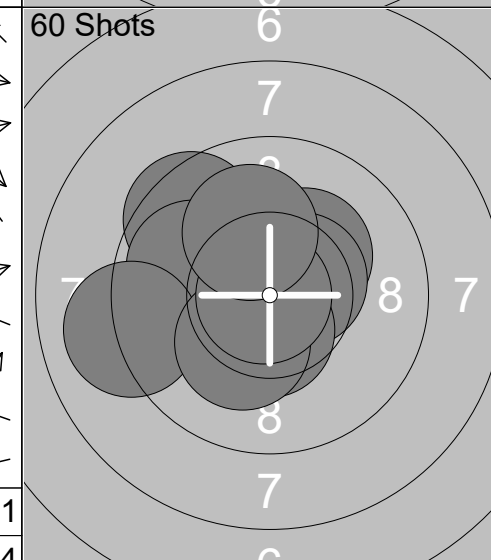

<p>60 Shots</p>  <p style="text-align: center;">6 7 8 7 8 7</p>	<p>1: 10.4x ← 2: 10.4x ↑ 3: 10.2x ← 4: 10.5x ↘ 5: 9.8 → 6: 10.7x ↙ 7: 10.6x ← 8: 9.8 ← 9: 10.6x ↓ 10: 10.0 ←</p> <p>Series 103.0 103.0</p>	<p>60 Shots</p>  <p style="text-align: center;">6 7 8 7 8 7</p>	<p>11: 10.6x ⇒ 12: 10.7x ↘ 13: 9.0 ↘ 14: 10.4x ⇒ 15: 10.6x ↗ 16: 10.2x ↙ 17: 10.3x ⇒ 18: 10.5x ↗ 19: 10.1 → 20: 10.2x ⇒</p> <p>Series 102.6 205.6</p>
<p>60 Shots</p>  <p style="text-align: center;">6 6 7 8 7 8 7</p>	<p>21: 10.2x ↓ 22: 10.2x ↑ 23: 10.1 ↓ 24: 10.2x ↓ 25: 10.1 ← 26: 10.3x ← 27: 10.6x ↖ 28: 10.6x ← 29: 10.5x ↙ 30: 10.7x ↗</p> <p>Series 103.5 309.1</p>	<p>60 Shots</p>  <p style="text-align: center;">6 6 7 8 7 8 7</p>	<p>31: 10.2x ← 32: 10.7x ↗ 33: 10.6x ↑ 34: 10.2x ↘ 35: 9.7 → 36: 10.1 ↙ 37: 10.9x ⇒ 38: 10.6x ← 39: 10.4x ⇒ 40: 10.8x ↗</p> <p>Series 104.2 413.3</p>
<p>60 Shots</p>  <p style="text-align: center;">6 6 7 8 7 8 7 6</p>	<p>41: 10.5x ↖ 42: 10.5x ⇒ 43: 10.1 → 44: 9.7 ↘ 45: 10.3x ↑ 46: 10.3x ⇒ 47: 10.2x ← 48: 10.2x ↑ 49: 10.0 ← 50: 10.3x ←</p> <p>Series 102.1 515.4</p>	<p>60 Shots</p>  <p style="text-align: center;">6 6 7 8 7 8 7 6</p>	<p>51: 9.5 ↖ 52: 10.7x ↘ 53: 9.9 ← 54: 9.1 ← 55: 10.3x ↗ 56: 10.5x ↗ 57: 10.5x ↓ 58: 10.2x ↙ 59: 10.9x ← 60: 10.1 ↑</p> <p>Series 101.7 617.1</p>

<b>Relay</b> <b>5</b>	<b>Lane</b> <b>21</b>	<b>Addy Burrow</b>
--------------------------	--------------------------	--------------------

WVU Mobile Range			
------------------	--	--	--

18.11.2023	Walther Cup 2023	West Virginia University
------------	------------------	--------------------------

Comment	Signature
---------	-----------

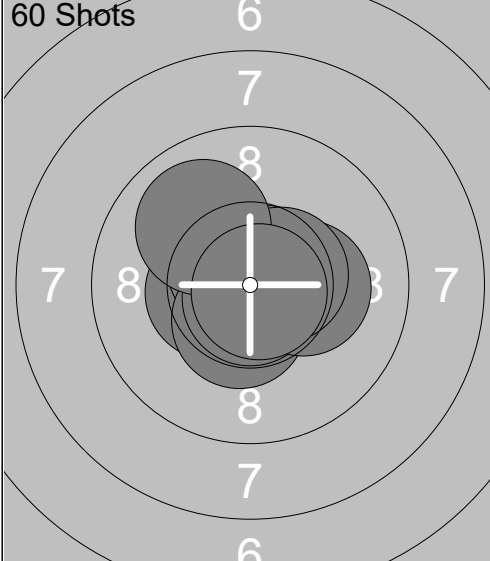
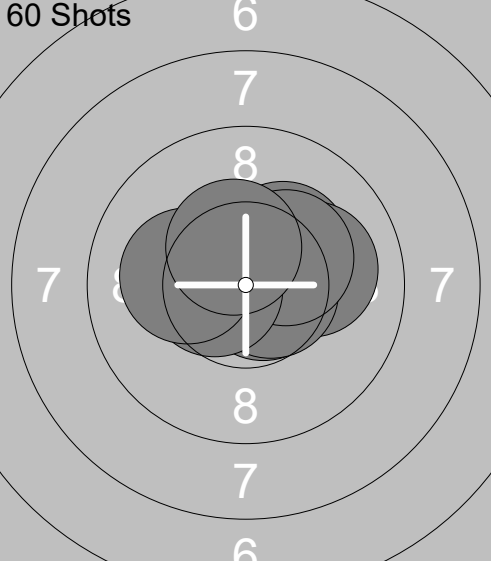
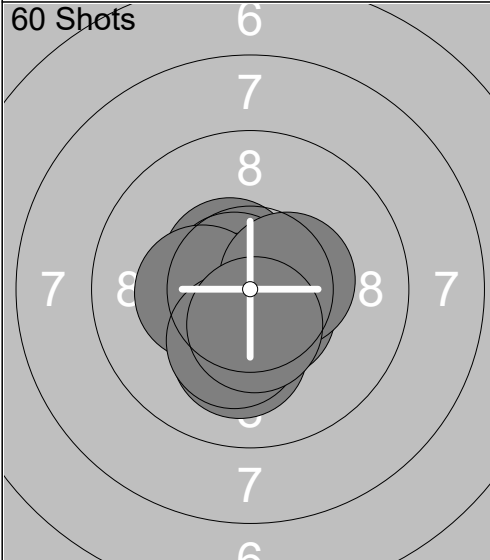
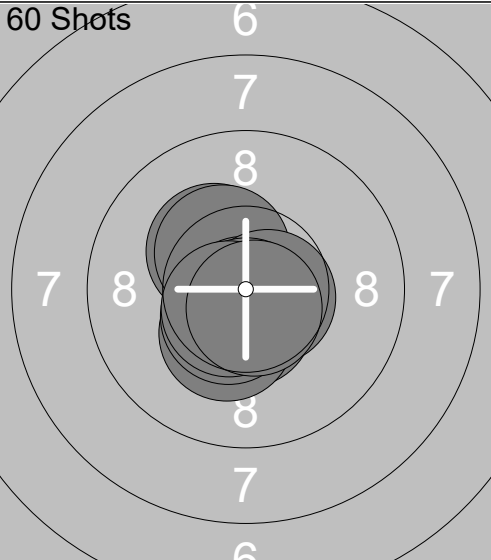
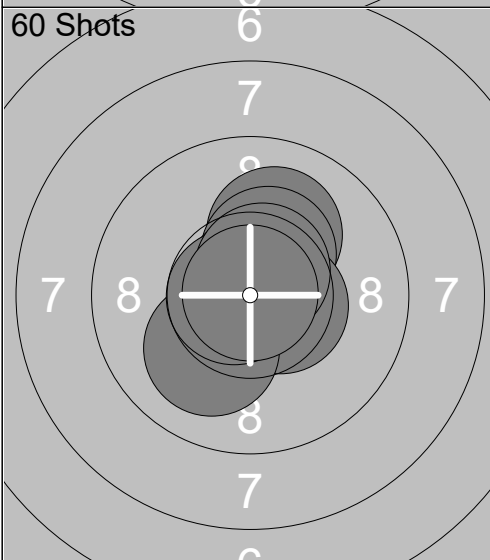
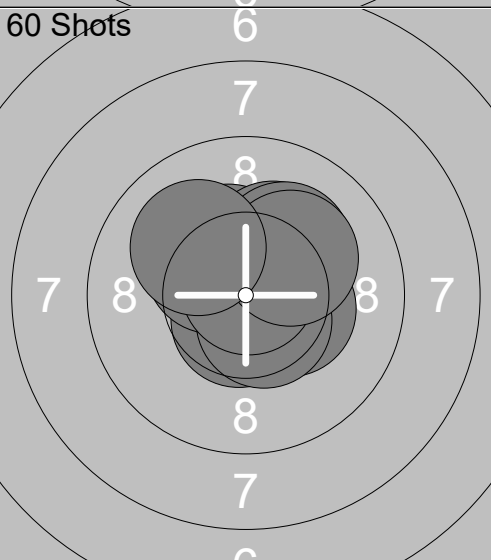
<p>60 Shots</p> 	<p>1: 10.5x ←</p> <p>2: 10.8x →</p> <p>3: 10.6x ↗</p> <p>4: 10.5x ↓</p> <p>5: 10.8x ↓</p> <p>6: 10.2x →</p> <p>7: 10.7x ↗</p> <p>8: 10.5x →</p> <p>9: 10.0 ↗</p> <p>10: 10.8x ↘</p> <p>Series 105.4</p> <p>105.4</p>	<p>60 Shots</p> 	<p>11: 10.5x ←</p> <p>12: 10.7x →</p> <p>13: 10.3x ↗</p> <p>14: 10.7x ↗</p> <p>15: 10.1 →</p> <p>16: 10.6x →</p> <p>17: 10.3x ↗</p> <p>18: 10.5x ←</p> <p>19: 10.2x ←</p> <p>20: 10.4x ↑</p> <p>Series 104.3</p> <p>209.7</p>
<p>60 Shots</p> 	<p>21: 10.5x ↗</p> <p>22: 10.7x ↙</p> <p>23: 10.1 ↓</p> <p>24: 10.7x ↖</p> <p>25: 10.6x ↘</p> <p>26: 10.7x ↙</p> <p>27: 10.3x ←</p> <p>28: 10.4x →</p> <p>29: 10.2x ↓</p> <p>30: 10.5x ↓</p> <p>Series 104.7</p> <p>314.4</p>	<p>60 Shots</p> 	<p>31: 10.5x ↓</p> <p>32: 10.3x ↖</p> <p>33: 10.4x ↖</p> <p>34: 10.7x ↓</p> <p>35: 10.6x →</p> <p>36: 10.3x ↓</p> <p>37: 10.7x ↓</p> <p>38: 10.5x ↙</p> <p>39: 10.6x ↙</p> <p>40: 10.7x ↘</p> <p>Series 105.3</p> <p>419.7</p>
<p>60 Shots</p> 	<p>41: 10.1 ↑</p> <p>42: 10.4x ↑</p> <p>43: 10.8x ↗</p> <p>44: 10.8x ↑</p> <p>45: 10.7x →</p> <p>46: 10.5x →</p> <p>47: 10.1 ↙</p> <p>48: 10.7x ←</p> <p>49: 10.6x ↑</p> <p>50: 10.9x ↑</p> <p>Series 105.6</p> <p>525.3</p>	<p>60 Shots</p> 	<p>51: 10.6x ↓</p> <p>52: 10.4x →</p> <p>53: 10.3x ↑</p> <p>54: 10.5x ↘</p> <p>55: 10.2x ↗</p> <p>56: 10.4x ↖</p> <p>57: 10.2x ↗</p> <p>58: 10.8x ↑</p> <p>59: 10.2x ↗</p> <p>60: 10.1 ↖</p> <p>Series 103.7</p> <p>629.0</p>

Relay <b>5</b>	Lane <b>22</b>	<b>Ty Travis</b>
-------------------	-------------------	------------------

WVU Mobile Range			
------------------	--	--	--

18.11.2023	Walther Cup 2023	West Virginia University
------------	------------------	--------------------------

Comment	Signature
---------	-----------

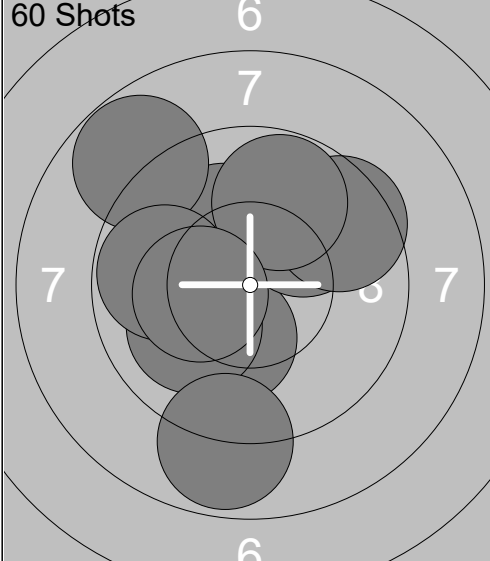
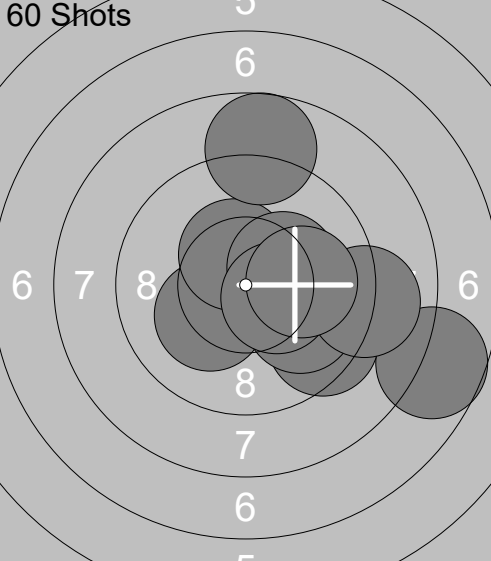
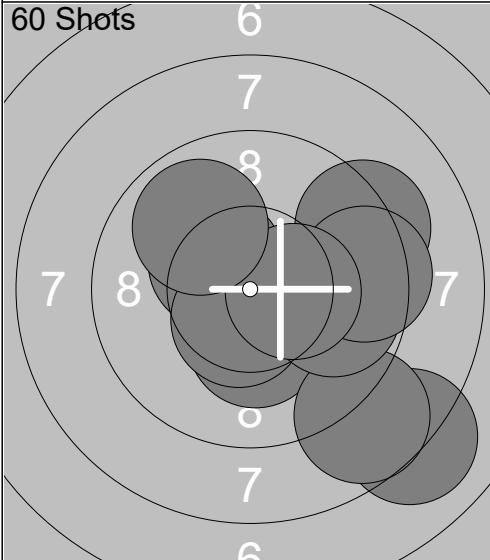
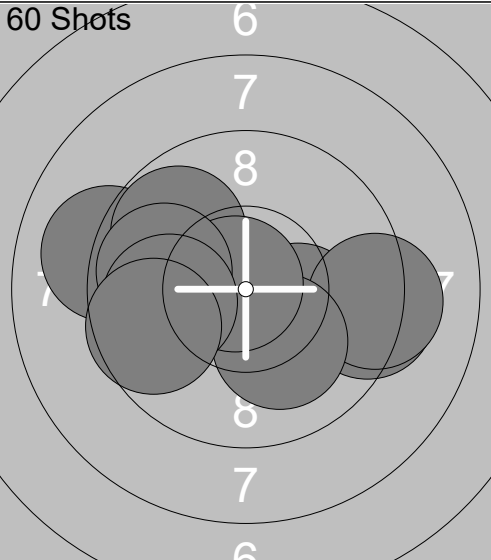
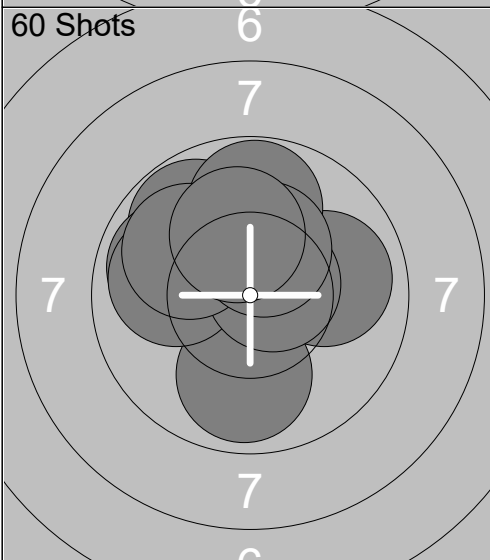
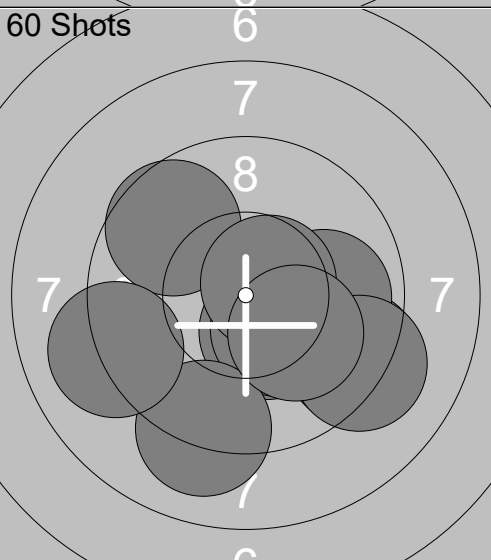
<p>60 Shots</p> 	<p>1: 10.2x ↘ 2: 10.0 ↙ 3: 10.2x ↗ 4: 8.8 ↖ 5: 9.9 ↗ 6: 9.5 ↗ 7: 9.8 ↗ 8: 8.9 ↓ 9: 9.8 ← 10: 10.3x ←</p> <p>Series 97.4 97.4</p>	<p>60 Shots</p> 	<p>11: 7.7 → 12: 9.4 ↘ 13: 10.2x ↙ 14: 9.9 ↘ 15: 9.0 → 16: 10.4x ↗ 17: 10.3x → 18: 10.4x → 19: 8.7 ↑ 20: 10.0 →</p> <p>Series 96.0 193.4</p>
<p>60 Shots</p> 	<p>21: 10.3x ↓ 22: 10.4x ↖ 23: 9.3 → 24: 8.1 ↘ 25: 10.5x ↓ 26: 8.7 ↓ 27: 9.8 → 28: 9.4 → 29: 10.4x → 30: 9.9 ↗</p> <p>Series 96.8 290.2</p>	<p>60 Shots</p> 	<p>31: 9.3 → 32: 10.2x → 33: 9.2 → 34: 9.1 ← 35: 10.1 ↓ 36: 9.8 ↗ 37: 10.8x ↖ 38: 9.8 ← 39: 9.9 ← 40: 9.6 ←</p> <p>Series 97.8 388.0</p>
<p>60 Shots</p> 	<p>41: 9.8 ↖ 42: 9.9 ↓ 43: 9.9 → 44: 9.9 ← 45: 9.9 ← 46: 10.6x → 47: 9.8 ↑ 48: 10.0 ↖ 49: 10.3x ↗ 50: 10.1 ↑</p> <p>Series 100.2 488.2</p>	<p>60 Shots</p> 	<p>51: 10.4x ↓ 52: 10.3x ↓ 53: 9.6 ↗ 54: 9.3 ↘ 55: 9.9 → 56: 10.6x → 57: 9.2 ↘ 58: 9.1 ↓ 59: 10.1 ↘ 60: 9.1 ←</p> <p>Series 97.6 585.8</p>

Relay <b>5</b>	Lane <b>23</b>	<b>Ian Lyons</b>
-------------------	-------------------	------------------

WVU Mobile Range			
------------------	--	--	--

18.11.2023	Walther Cup 2023	West Virginia University
------------	------------------	--------------------------

Comment	Signature
---------	-----------

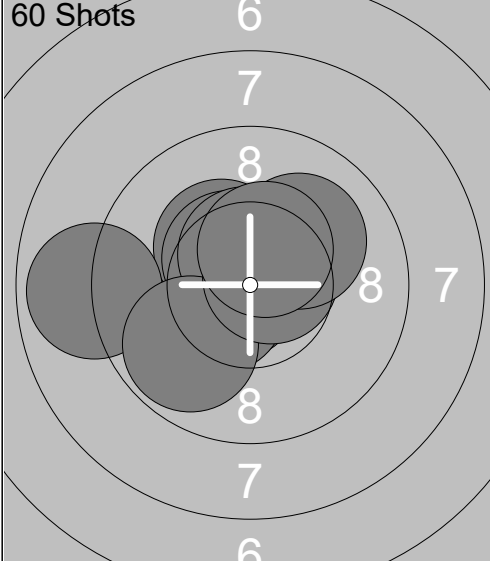
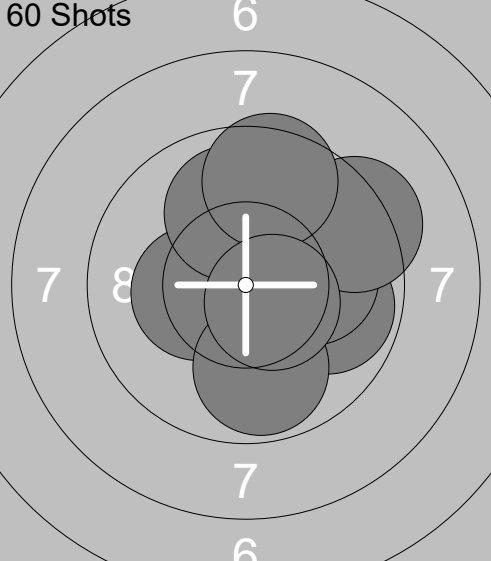
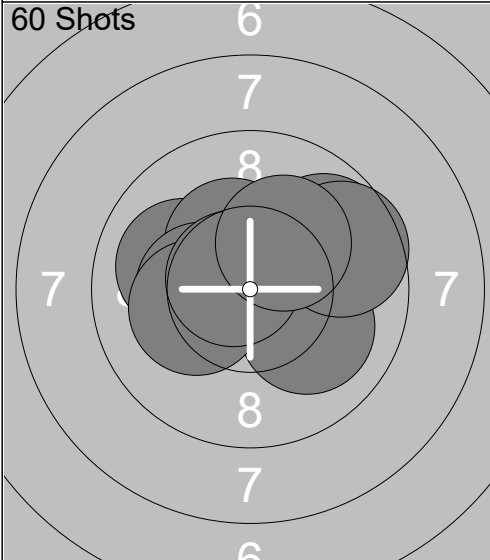
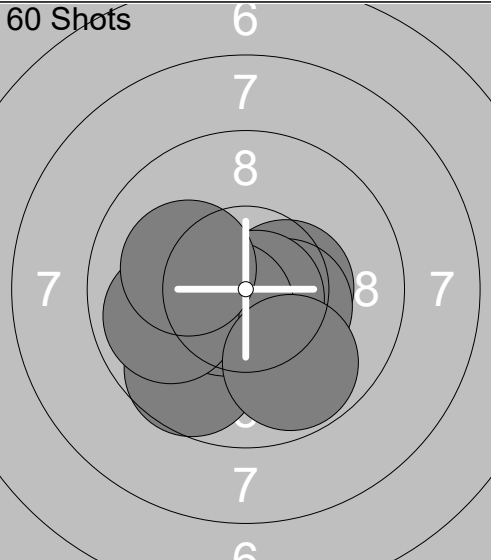
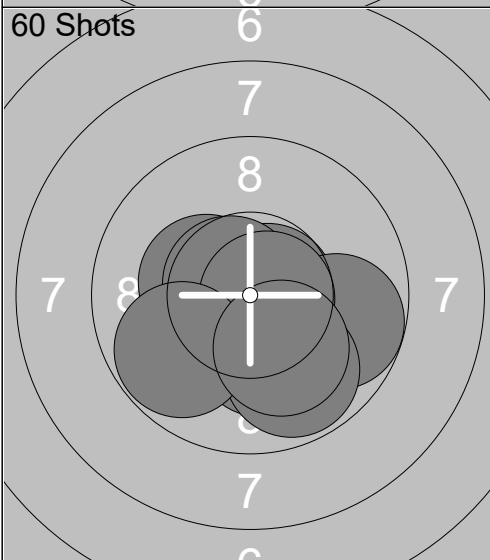
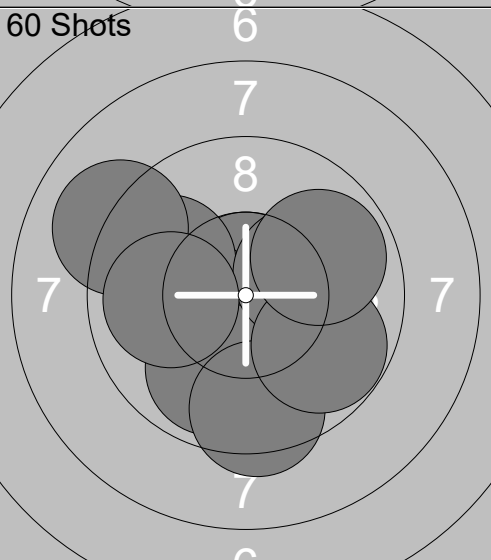
<p>60 Shots</p> 	<p>1: 10.7x ←</p> <p>2: 10.4x ←</p> <p>3: 10.3x ↗</p> <p>4: 8.9 ←</p> <p>5: 10.5x ↗</p> <p>6: 10.5x ↑</p> <p>7: 9.8 ↘</p> <p>8: 10.7x →</p> <p>9: 10.1 ↗</p> <p>10: 10.4x ↑</p> <hr/> <p>Series 102.3</p> <p style="text-align: center;">102.3</p>	<p>60 Shots</p> 	<p>11: 10.7x ↓</p> <p>12: 9.8 →</p> <p>13: 10.7x ↑</p> <p>14: 10.1 →</p> <p>15: 10.3x ←</p> <p>16: 10.0 ↑</p> <p>17: 9.3 ↗</p> <p>18: 9.5 ↑</p> <p>19: 9.8 ↓</p> <p>20: 10.5x ↘</p> <hr/> <p>Series 100.7</p> <p style="text-align: center;">203.0</p>
<p>60 Shots</p> 	<p>21: 10.1 ↘</p> <p>22: 9.8 ↗</p> <p>23: 9.6 ↗</p> <p>24: 10.0 ←</p> <p>25: 10.3x ←</p> <p>26: 10.3x ↑</p> <p>27: 10.3x ←</p> <p>28: 10.2x ←</p> <p>29: 10.7x ↖</p> <p>30: 10.2x ↗</p> <hr/> <p>Series 101.5</p> <p style="text-align: center;">304.5</p>	<p>60 Shots</p> 	<p>31: 10.6x ↓</p> <p>32: 10.4x →</p> <p>33: 9.7 ↘</p> <p>34: 10.7x ←</p> <p>35: 10.4x →</p> <p>36: 10.8x ↘</p> <p>37: 10.6x ↘</p> <p>38: 9.9 ←</p> <p>39: 9.8 ↓</p> <p>40: 10.1 ←</p> <hr/> <p>Series 103.0</p> <p style="text-align: center;">407.5</p>
<p>60 Shots</p> 	<p>41: 10.2x ↓</p> <p>42: 10.7x →</p> <p>43: 10.2x ↓</p> <p>44: 10.3x ←</p> <p>45: 10.7x ↖</p> <p>46: 9.8 →</p> <p>47: 10.7x →</p> <p>48: 9.8 ↓</p> <p>49: 9.8 ←</p> <p>50: 10.1 ↓</p> <hr/> <p>Series 102.3</p> <p style="text-align: center;">509.8</p>	<p>60 Shots</p> 	<p>51: 10.8x ↑</p> <p>52: 10.3x ←</p> <p>53: 9.9 ↓</p> <p>54: 9.8 ←</p> <p>55: 9.4 ↓</p> <p>56: 10.2x →</p> <p>57: 9.8 ↘</p> <p>58: 9.1 ↖</p> <p>59: 9.9 ↗</p> <p>60: 10.0 ←</p> <hr/> <p>Series 99.2</p> <p style="text-align: center;">609.0</p>

<p>60 Shots</p>	<p>1: 10.1 ↗ 2: 10.0 ↘ 3: 10.5x → 4: 9.6 ↘ 5: 10.1 ← 6: 9.9 ↗ 7: 10.0 ↗ 8: 10.0 ↗ 9: 10.2x ↗ 10: 10.5x ↗</p> <p>Series 100.9 100.9</p>	<p>60 Shots</p>	<p>11: 10.6x ← 12: 9.8 ← 13: 9.5 → 14: 9.4 → 15: 9.9 ← 16: 9.7 ← 17: 10.4x ↗ 18: 10.1 ↓ 19: 10.2x ↗ 20: 10.1 ↘</p> <p>Series 99.7 200.6</p>
<p>60 Shots</p>	<p>21: 9.8 ↗ 22: 9.5 ↓ 23: 10.0 ↘ 24: 10.5x ↗ 25: 10.3x ↗ 26: 9.8 ↗ 27: 10.2x ↗ 28: 9.8 ↗ 29: 10.4x ← 30: 10.9x ↓</p> <p>Series 101.2 301.8</p>	<p>60 Shots</p>	<p>31: 9.9 → 32: 9.6 ↗ 33: 10.4x ↗ 34: 10.7x ← 35: 9.7 → 36: 10.3x ↗ 37: 10.0 ↓ 38: 8.9 → 39: 10.7x ↗ 40: 10.5x ↗</p> <p>Series 100.7 402.5</p>
<p>60 Shots</p>	<p>41: 10.3x ← 42: 9.6 → 43: 9.8 ↓ 44: 9.9 ← 45: 9.6 → 46: 10.5x → 47: 9.9 ↗ 48: 10.7x ↓ 49: 10.6x ↓ 50: 10.3x ←</p> <p>Series 101.2 503.7</p>	<p>60 Shots</p>	<p>51: 10.7x ← 52: 10.3x ← 53: 9.8 ↗ 54: 10.3x ← 55: 10.4x ← 56: 10.5x ← 57: 10.5x ← 58: 10.4x ↓ 59: 10.2x ↗ 60: 10.7x →</p> <p>Series 103.8 607.5</p>

Relay <b>5</b>	Lane <b>25</b>	<b>Jason Raba</b>
-------------------	-------------------	-------------------

WVU Mobile Range		
------------------	--	--

18.11.2023	Walther Cup 2023	West Virginia University
------------	------------------	--------------------------

Comment	Signature
---------	-----------

<p>60 Shots</p>	<p>1: 9.5 ↗ 2: 10.0 ↗ 3: 10.0 ↗ 4: 10.4x ↗ 5: 10.0 ↗ 6: 10.4x ↘ 7: 9.6 ↘ 8: 10.6x ↗ 9: 9.3 ← 10: 10.2x ↗</p> <p>Series 100.0 100.0</p>	<p>60 Shots</p>	<p>11: 9.4 ↘ 12: 9.7 ← 13: 9.5 → 14: 9.4 → 15: 10.3x ↓ 16: 9.4 ↘ 17: 8.9 ↘ 18: 9.9 → 19: 8.9 ← 20: 10.9x ↗</p> <p>Series 96.3 196.3</p>
<p>60 Shots</p>	<p>21: 10.7x ↗ 22: 9.7 → 23: 7.8 ← 24: 9.7 → 25: 8.8 ← 26: 10.2x ↗ 27: 10.3x → 28: 9.5 → 29: 10.1 ↘ 30: 10.3x ←</p> <p>Series 97.1 293.4</p>	<p>60 Shots</p>	<p>31: 9.8 ← 32: 10.2x ↗ 33: 10.4x ↗ 34: 9.8 ← 35: 10.3x ↗ 36: 9.1 → 37: 9.9 ↘ 38: 8.3 ↗ 39: 10.2x ↓ 40: 8.8 ←</p> <p>Series 96.8 390.2</p>
<p>60 Shots</p>	<p>41: 9.7 ↗ 42: 9.6 ← 43: 10.1 ← 44: 9.9 → 45: 9.1 ↗ 46: 9.8 → 47: 10.0 ↗ 48: 9.5 ↗ 49: 8.4 ← 50: 9.5 ←</p> <p>Series 95.6 485.8</p>	<p>60 Shots</p>	<p>51: 8.3 ← 52: 10.1 ← 53: 10.4x ↗ 54: 8.3 ← 55: 9.8 ← 56: 10.6x ↗ 57: 9.9 ↘ 58: 9.3 ↘ 59: 10.8x ↗ 60: 10.1 ↗</p> <p>Series 97.6 583.4</p>

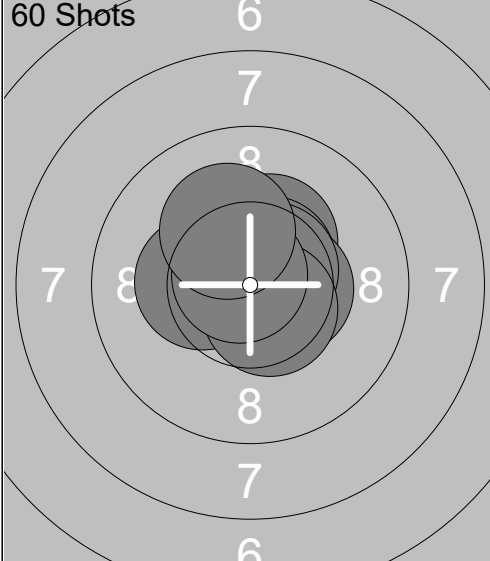
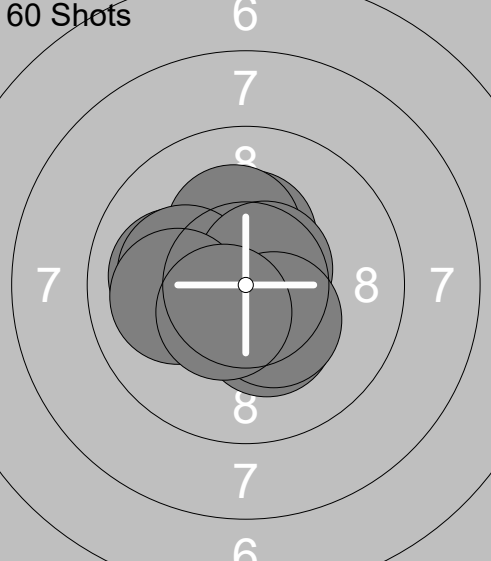
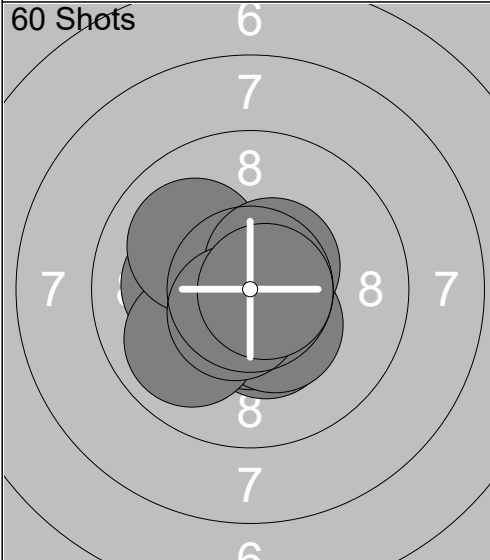
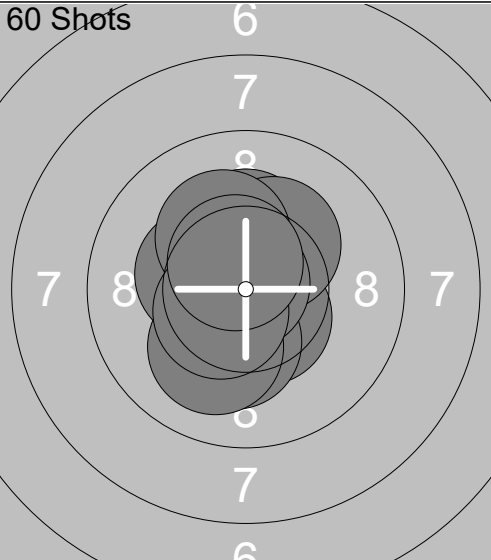
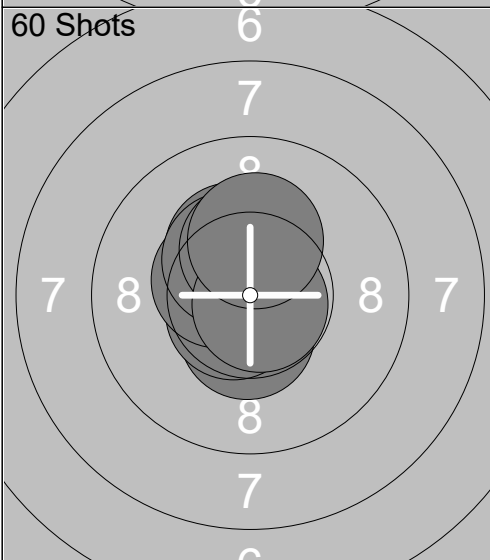
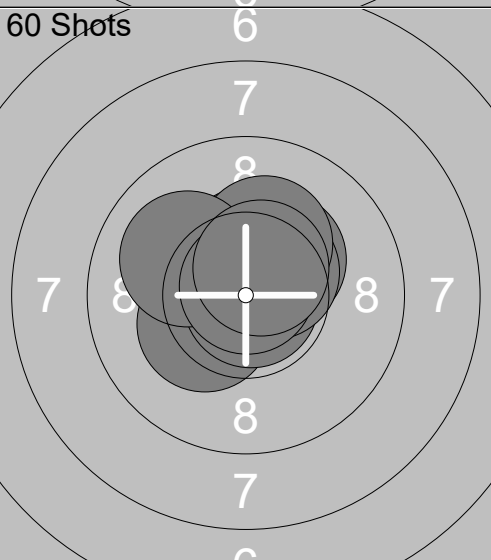
<p>60 Shots</p> 	<p>1: 10.6x ↗ 2: 10.3x ↑ 3: 10.6x ↗ 4: 10.6x ↘ 5: 10.5x → 6: 10.6x ↗ 7: 10.3x ← 8: 10.5x ↘ 9: 10.8x ↗ 10: 10.2x ↑</p> <p>Series 105.0 105.0</p>	<p>60 Shots</p> 	<p>11: 10.0 ← 12: 10.3x ↑ 13: 10.4x ← 14: 10.2x ↑ 15: 10.1 ← 16: 10.6x ↗ 17: 10.3x ↘ 18: 10.0 ← 19: 10.4x ↘ 20: 10.5x ↘</p> <p>Series 102.8 207.8</p>
<p>60 Shots</p> 	<p>21: 10.4x ↘ 22: 10.5x ← 23: 10.1 ← 24: 10.5x ↘ 25: 10.4x ↘ 26: 9.9 ← 27: 10.0 ↖ 28: 10.5x ↗ 29: 10.6x ↘ 30: 10.8x →</p> <p>Series 103.7 311.5</p>	<p>60 Shots</p> 	<p>31: 10.3x ↑ 32: 10.5x ↘ 33: 10.2x ↘ 34: 10.3x ← 35: 10.1 ↘ 36: 10.3x ↗ 37: 10.2x ↑ 38: 10.9x ↖ 39: 10.5x ↘ 40: 10.6x ↑</p> <p>Series 103.9 415.4</p>
<p>60 Shots</p> 	<p>41: 10.8x ← 42: 10.6x ↑ 43: 10.3x ↑ 44: 10.5x ↘ 45: 10.6x ↘ 46: 10.5x ↖ 47: 10.4x ↗ 48: 10.3x ↑ 49: 10.8x ↘ 50: 10.2x ↑</p> <p>Series 105.0 520.4</p>	<p>60 Shots</p> 	<p>51: 10.5x ↖ 52: 10.3x ↖ 53: 10.3x ↗ 54: 10.9x ↘ 55: 10.4x ↑ 56: 10.5x ↗ 57: 10.2x ↑ 58: 10.0 ↖ 59: 10.8x ↑ 60: 10.5x ↗</p> <p>Series 104.4 624.8</p>